EMC Test Report

Report No.: AGC12440230905ER01

PRODUCT DESIGNATION : Wireless speaker
BRAND NAME : N/A
MODEL NAME : M08726
APPLICANT : Mid Ocean Brands B.V.
DATE OF ISSUE : Oct. 10, 2023
STANDARD(S) : ETSI EN 301 489-1 V2.2.3 (2019-11)
: ETSI EN 301 489-17 V3.2.4 (2020-09)
REPORT VERSION : V1.0

Attestation of Global Compliance (Shenzhen) Co., Ltd



Any report having not been signed by authorized approver, or having been altered without authorization, or having not been stamped by the "Dedicated Testing/Inspection Stamp" is deemed to be invalid. Copying or excerpting portion of, or altering the content of the report is not permitted without the written authorization of AGC. The test results presented in the report apply only to the tested sample. Any objections to report issued by AGC should be submitted to AGC within 15days after the issuance of the test report. Further enquiry of validity or verification of the test report should be addressed to AGC by agc01@agccert.com.

Attestation of Global Compliance(Shenzhen)Co., Ltd
Attestation of Global Compliance(Shenzhen)Std & Tech Co., Ltd
Tel: +86-755 2523 4088 E-mail: agc@agccert.com Web: <http://www.agccert.com/>



REPORT REVISE RECORD

Report Version	Revise Time	Issued Date	Valid Version	Notes
V1.0	/	Oct. 10, 2023	Valid	Initial release

Any report having not been signed by authorized approver, or having been altered without authorization, or having not been stamped by the "Dedicated Testing/Inspection Stamp" is deemed to be invalid. Copying or excerpting portion of, or altering the content of the report is not permitted without the written authorization of AGC. The test results presented in the report apply only to the tested sample. Any objections to report issued by AGC should be submitted to AGC within 15days after the issuance of the test report. Further enquiry of validity or verification of the test report should be addressed to AGC by agc01@agccert.com.

Attestation of Global Compliance(Shenzhen)Co., Ltd
Attestation of Global Compliance(Shenzhen)Std & Tech Co., Ltd
Tel: +86-755 2523 4088 E-mail: agc@agccert.com Web: <http://www.agccert.com/>

TABLE OF CONTENTS

1. TEST REPORT CERTIFICATION6

2. GENERAL INFORMATION 7

 2.1. DESCRIPTION OF EUT 7

 2.2. OBJECTIVE7

 2.3. TEST STANDARDS AND RESULTS 7

 2.4. TEST ITEMS AND THE RESULTS8

 2.5. ENVIRONMENTAL CONDITIONS8

3. TEST MODE DESCRIPTION 9

4. MEASUREMENT UNCERTAINTY10

5. SUPPORT EQUIPMENT 10

6. IDENTIFICATION OF THE RESPONSIBLE TESTING LOCATION 11

7. RADIATED DISTURBANCE MEASUREMENT 13

 7.1. LIMITS OF RADIATED DISTURBANCES 13

 7.2. TEST PROCEDURE 13

 7.3. BLOCK DIAGRAM OF TEST SETUP14

7.4. TEST RESULT 15

8. CONDUCTED EMISSION MEASUREMENT 19

 8.1. LIMITS OF LINE CONDUCTED EMISSION 19

 8.2. TEST PROCEDURE 19

 8.3. TEST SETUP 20

 8.4. TEST RESULT 21

9. HARMONIC CURRENT MEASUREMENT23

 9.1. LIMITS OF HARMONIC CURRENT23

 9.2. TEST PROCEDURE 23

 9.3. TEST SETUP 24

 9.4. TEST RESULT 24

10. VOLTAGE FLUCTUATIONS AND FLICK MEASUREMENT 25

 10.1. LIMITS OF VOLTAGE FLUCTUATIONS AND FLICK25

 10.2. TEST PROCEDURE 25

Any report having not been signed by authorized approver, or having been altered without authorization, or having not been stamped by the “Dedicated Testing/Inspection Stamp” is deemed to be invalid. Copying or excerpting portion of, or altering the content of the report is not permitted without the written authorization of AGC. The test results presented in the report apply only to the tested sample. Any objections to report issued by AGC should be submitted to AGC within 15days after the issuance of the test report. Further enquiry of validity or verification of the test report should be addressed to AGC by agc01@agccert.com.

10.3. TEST SETUP	25
10.4. TEST RESULT	25
11. IMMUNITY TEST	26
11.1. DESCRIPTION OF PERFORMANCE CRITERIA	26
11.2. GENERAL PERFORMANCE CRITERIA	26
12. ELECTROSTATIC DISCHARGE IMMUNITY TEST	28
12.1 TEST SPECIFICATION	28
12.2 TEST PROCEDURE	28
12.3 TEST SETUP	29
12.4 TEST RESULT	31
12.5 PERFORMANCE	31
13. RADIATED, RADIO FREQUENCY ELECTROMAGNETIC FIELD IMMUNITY TEST	32
13.1. TEST SPECIFICATION	32
13.2. TEST PROCEDURE	32
13.3. TEST SETUP	33
13.4. TEST RESULT	34
13.5. PERFORMANCE	34
14. ELECTRICAL FAST TRANSIENT/BURST IMMUNITY TEST	35
14.1. TEST SPECIFICATION	35
14.2. TEST PROCEDURE	35
14.3. TEST SETUP	35
14.4. TEST RESULT	36
14.5. PERFORMANCE	36
15. SURGE IMMUNITY TEST	37
15.1. TEST SPECIFICATION	37
15.2. TEST PROCEDURE	37
15.3. TEST SETUP	37
15.4. TEST RESULT	38
15.5. PERFORMANCE	38
16. IMMUNITY TO CONDUCTED DISTURBANCES INDUCED BY RF FIELDS	39
16.1. TEST SPECIFICATION	39
16.2. TEST PROCEDURE	39

Any report having not been signed by authorized approver, or having been altered without authorization, or having not been stamped by the “Dedicated Testing/Inspection Stamp” is deemed to be invalid. Copying or excerpting portion of, or altering the content of the report is not permitted without the written authorization of AGC. The test results presented in the report apply only to the tested sample. Any objections to report issued by AGC should be submitted to AGC within 15days after the issuance of the test report. Further enquiry of validity or verification of the test report should be addressed to AGC by agc01@agccert.com.

16.3. TEST SETUP 39

16.4. TEST RESULT 40

16.5. PERFORMANCE 40

17. VOLTAGE DIPS AND SHORT INTERRUPTIONS IMMUNITY TEST 41

17.1. TEST SPECIFICATION41

17.2. TEST PROCEDURE 41

17.3. TEST SETUP 41

17.4. TEST RESULT 42

17.5. PERFORMANCE 42

APPENDIX A: PHOTOGRAPHS OF TEST SETUP43



APPENDIX B: PHOTOGRAPHS OF EUT48

Any report having not been signed by authorized approver, or having been altered without authorization, or having not been stamped by the “Dedicated Testing/Inspection Stamp” is deemed to be invalid. Copying or excerpting portion of, or altering the content of the report is not permitted without the written authorization of AGC. The test results presented in the report apply only to the tested sample. Any objections to report issued by AGC should be submitted to AGC within 15days after the issuance of the test report. Further enquiry of validity or verification of the test report should be addressed to AGC by agc01@agccert.com.

1. TEST REPORT CERTIFICATION

Applicant	Mid Ocean Brands B.V.
Address	7/F., King Tower, 111King Lam Street, Cheung ShaWan, Kowloon, HongKong.
Manufacturer	Mid Ocean Brands B.V.
Address	7/F., King Tower, 111King Lam Street, Cheung ShaWan, Kowloon, HongKong.
Factory	Mid Ocean Brands B.V.
Address	7/F., King Tower, 111King Lam Street, Cheung ShaWan, Kowloon, HongKong.
Product Designation	Wireless speaker
Brand Name	N/A
Test Model	MO8726
Series Model	N/A
Difference Description	N/A
Date of receipt of test item	Sep. 25, 2023
Date of test	Sep. 25, 2023 to Oct. 09, 2021
Deviation	None
Condition of Test Sample	Normal
Test Result	Pass
Report Template	AGCRT-EC-EMC

We, Attestation of Global Compliance (Shenzhen) Co., Ltd., hereby certify that the submitted samples of the above item, as detailed in chapter 2.1 of this report, has been tested in our facility. The test record, data evaluation and test configuration represented herein are true and accurate accounts of measurements of the sample's EMC characteristics under the conditions herein specified.

Prepared By	 <hr/> Sky Zhou (Project Engineer)	Oct. 10, 2023
Reviewed By	 <hr/> Calvin Liu (Reviewer)	Oct. 10, 2023
Approved By	 <hr/> Max Zhang (Authorized Officer)	Oct. 10, 2023

Any report having not been signed by authorized approver, or having been altered without authorization, or having not been stamped by the "Dedicated Testing/Inspection Stamp" is deemed to be invalid. Copying or excerpting portion of, or altering the content of the report is not permitted without the written authorization of AGC. The test results presented in the report apply only to the tested sample. Any objections to report issued by AGC should be submitted to AGC within 15days after the issuance of the test report. Further enquiry of validity or verification of the test report should be addressed to AGC by agc01@agccert.com.

2. GENERAL INFORMATION

2.1. DESCRIPTION OF EUT

The EUT is a short range, lower power, Bluetooth device.

Details of technical specification refer to the description in follows:

Transmitter/Receiver (TX/RX)

Operating Frequency	2402MHz to 2480MHz
Bluetooth Version	V5.3
Modulation Type	BR <input checked="" type="checkbox"/> GFSK 1Mbps; EDR <input checked="" type="checkbox"/> π /4-DQPSK 2Mbps <input checked="" type="checkbox"/> 8DPSK 3Mbps BLE <input type="checkbox"/> GFSK 1Mbps <input type="checkbox"/> GFSK 2Mbps
Number of channels	79 Channels for BR/EDR
Hardware Version	V2.0
Software Version	ac696n_soundbox_sdk_v1.6.0
Antenna Type	PCB Antenna
Antenna Gain	1.2dBi
Power Supply	DC 3.7V by battery or DC 5V by adapter

2.2. OBJECTIVE

Perform Electro Magnetic Interference (EMI) and Electro Magnetic Susceptibility (EMS) tests for CE Marking.

2.3. TEST STANDARDS AND RESULTS

The EUT has been tested according to ETSI EN 301 489-1 V2.2.3 (2019-11) and ETSI EN 301 489-17 V3.2.4 (2020-09).

ETSI EN 301 489-1	ElectroMagnetic Compatibility (EMC) standard for radio equipment and services; Part 1: Common technical requirements; Harmonised Standard for ElectroMagnetic Compatibility.
ETSI EN 301 489-17	ElectroMagnetic Compatibility (EMC) standard for radio equipment and services; Part 17: Specific conditions for Broadband Data Transmission Systems; Harmonised Standard for ElectroMagnetic Compatibility

Any report having not been signed by authorized approver, or having been altered without authorization, or having not been stamped by the "Dedicated Testing/Inspection Stamp" is deemed to be invalid. Copying or excerpting portion of, or altering the content of the report is not permitted without the written authorization of AGC. The test results presented in the report apply only to the tested sample. Any objections to report issued by AGC should be submitted to AGC within 15days after the issuance of the test report. Further enquiry of validity or verification of the test report should be addressed to AGC by agc01@agccert.com.

2.4. TEST ITEMS AND THE RESULTS

No.	Basic Standard	Test Type	Result
EMISSION (EN 301 489-1 §7.1)			
1	EN 55032	Radiated emission	PASS
2	EN 55032	Conducted emission, AC ports	PASS
3	EN 55032	Conducted emission, Telecom ports	N/A
4	EN 61000-3-2	Harmonic current emissions	N/A
5	EN 61000-3-3	Voltage fluctuations & flicker	PASS
IMMUNITY (EN 301 489-1 §7.2)			
6	EN 61000-4-2	Electrostatic discharge immunity	PASS
7	EN 61000-4-3	Radiated RF electromagnetic field immunity	PASS
8	EN 61000-4-4	Electrical fast transient/burst immunity	PASS
9	ISO 7637-1, -2	Transients and surges, DC ports	N/A
10	EN 61000-4-5	Surge immunity, AC ports, Telecom ports	PASS
11	EN 61000-4-6	Immunity to conducted disturbances induced by RF fields	PASS
12	EN 61000-4-11	Voltage dips and short interruptions immunity	PASS

Note: 1. N/A- Not Applicable.
2. The latest versions of basic standards are applied.

2.5. ENVIRONMENTAL CONDITIONS

During the measurement the environmental conditions were within the listed ranges:

- Temperature: 15-35°C
- Relative humidity: 30-60%
- Atmospheric pressure: 86-106kPa

Any report having not been signed by authorized approver, or having been altered without authorization, or having not been stamped by the "Dedicated Testing/Inspection Stamp" is deemed to be invalid. Copying or excerpting portion of, or altering the content of the report is not permitted without the written authorization of AGC. The test results presented in the report apply only to the tested sample. Any objections to report issued by AGC should be submitted to AGC within 15days after the issuance of the test report. Further enquiry of validity or verification of the test report should be addressed to AGC by agc01@agccert.com.

Attestation of Global Compliance(Shenzhen)Co., Ltd
Attestation of Global Compliance(Shenzhen)Std & Tech Co., Ltd
Tel: +86-755 2523 4088 E-mail: agc@agccert.com Web: http://www.agccert.com/

3. TEST MODE DESCRIPTION

TEST MODE DESCRIPTION		
NO.	EMI TEST MODE DESCRIPTION	WORST
1	BT mode	--
2	BT mode with charging	--
NO.	EMS TEST MODE DESCRIPTION	WORST
1	BT mode	--
2	BT mode with charging	--

Note: All modes have been tested and only the worst mode test data recorded in the test report.

I/O Port Information (Applicable Not Applicable)

I/O Port of EUT			
I/O Port Type	Number	Cable Description	Tested With
Type-C	1	50cm	1
AUX	1	1m	1

Any report having not been signed by authorized approver, or having been altered without authorization, or having not been stamped by the "Dedicated Testing/Inspection Stamp" is deemed to be invalid. Copying or excerpting portion of, or altering the content of the report is not permitted without the written authorization of AGC. The test results presented in the report apply only to the tested sample. Any objections to report issued by AGC should be submitted to AGC within 15days after the issuance of the test report. Further enquiry of validity or verification of the test report should be addressed to AGC by agc01@agccert.com.

4. MEASUREMENT UNCERTAINTY

The uncertainty is calculated using the methods suggested in the “Guide to the Expression of Uncertainty in measurement” (GUM) published by CISPR and ANSI.

- Uncertainty of Conducted Emission, $U_c = \pm 2.9$ dB
- Uncertainty of Radiated Emission below 1GHz, $U_c = \pm 3.9$ dB
- Uncertainty of Radiated Emission above 1GHz, $U_c = \pm 4.9$ dB

5. SUPPORT EQUIPMENT

Device Type	Manufacturer	Model Name	Data Cable
iPod	APPLE	MGG82ZP/A	N/A
SD card	Changhong	N/A	N/A
Adapter	jinbaotong	K-T10E0502000E	N/A

- Note: 1. “--” means no any support device during testing.
2. All the cables were provided by AGC Lab.

6. IDENTIFICATION OF THE RESPONSIBLE TESTING LOCATION

Site	Attestation of Global Compliance (Shenzhen) Co., Ltd
Location	1-2/F, Building 19, Junfeng Industrial Park, Chongqing Road, Heping Community, Fuhai Street, Bao'an District, Shenzhen, Guangdong, China

TEST EQUIPMENT OF CONDUCTED EMISSION TEST

Equipment	Manufacturer	Model	S/N	Cal. Date	Cal. Due
Test Receiver	R&S	ESPI	101206	Jun. 03, 2023	Jun. 02, 2024
Artificial power network	R&S	ESH2-Z5	100086	Jun. 03, 2023	Jun. 02, 2024
Test software	R&S	ES-K1	Ver.V1.7.1	N/A	N/A

TEST EQUIPMENT OF RADIATED EMISSION TEST

Equipment	Manufacturer	Model	S/N	Cal. Date	Cal. Due
Test Receiver	R&S	ESCI	10096	Feb. 18, 2023	Feb. 17, 2024
EXA Signal Analyzer	Aglient	N9010A	MY53470504	Jun. 01, 2023	May 31, 2024
Double-Ridged Waveguide Horn	ETS LINDGREN	3117	00034609	Mar. 23, 2023	Mar. 22, 2024
Preamplifier Assembly	ETS	3117PA	00225134	Sep. 02, 2022	Sep. 01, 2024
Wideband Antenna	SCHWARZBEC K	VULB9168	VULB9168-494	Jan. 05, 2023	Jan. 04, 2025
Test Software	FARA	EZ-EMC(Ver.RA-03A)	N/A	N/A	N/A
Test Software	Tonscend	JS32-RE(Ver.2.5)	N/A	N/A	N/A

TEST EQUIPMENT OF POWER HARMONICS / VOLTAGE FLUCTUATION / FLICKER TEST

Equipment	Manufacturer	Model	S/N	Cal. Date	Cal. Due
Signal Conditioning Unit	Schaffner	CCN1000-1	72431	Jun. 08, 2023	Jun. 07, 2024
AC Source	Schaffner	NSG1007	56825	Jun. 02, 2023	Jun. 01, 2024

TEST EQUIPMENT OF ESD TEST

Equipment	Manufacturer	Model	S/N	Cal. Date	Cal. Due
ESD Simulator	Schaffner	NSG 438	782	Dec. 30, 2022	Dec. 29, 2023

Any report having not been signed by authorized approver, or having been altered without authorization, or having not been stamped by the "Dedicated Testing/Inspection Stamp" is deemed to be invalid. Copying or excerpting portion of, or altering the content of the report is not permitted without the written authorization of AGC. The test results presented in the report apply only to the tested sample. Any objections to report issued by AGC should be submitted to AGC within 15days after the issuance of the test report. Further enquiry of validity or verification of the test report should be addressed to AGC by agc01@agccert.com.

TEST EQUIPMENT OF SURGE/EFT/DIPS TEST

Equipment	Manufacturer	Model	S/N	Cal. Date	Cal. Due
EFT/Surge Generator	Schaffner	Modula 6150	34437	Jun. 08, 2023	Jun. 07, 2024

TEST EQUIPMENT OF RS IMMUNITY TEST

Equipment	Manufacturer	Model	S/N	Cal. Date	Cal. Due
Signal Generator	Agilent	N5182A	MY50140530	Feb. 17, 2023	Feb. 16, 2024
Directional coupler	Werlatone	C5571-10	99463	Mar. 10, 2022	Mar. 09, 2024
Directional coupler	Werlatone	C5571-10	99482	Mar. 10, 2022	Mar. 09, 2024
Power Meter	R&S	NRVD	8323781027	Mar. 24, 2022	Mar. 23, 2025
Power Amplifier	KALMUS	7100LC	04-02/17-06-001	N/A	N/A
Power Amplifier	Milmega	AS0104-55_55	1004793	N/A	N/A
Power amplifier	rflight	NTWPA-256010 0	17063183	N/A	N/A
Biconilog Antenna	ETS	3142C	00060447	N/A	N/A
Broadband high gain horn antenna	SCHWARZBEC K	BBHA 9120 J	00073	N/A	N/A
Test Software	Tonscend	2.0.1.8	N/A	N/A	N/A

TEST EQUIPMENT OF CS IMMUNITY TEST

Equipment	Manufacturer	Model	S/N	Cal. Date	Cal. Due
Power Amplifier	AR	75A250	18464	N/A	N/A
CDN	ZHINAN	ZN3751	15004	Aug. 03, 2022	Sep. 02, 2024
6dB attenuator	ZHINAN	E-002	N/A	Aug. 04, 2022	Aug. 03, 2024
Power Probe	R&S	URV5-Z4	100124	Mar. 24, 2023	Mar. 23, 2025
Electromagnetic Injection Clamp	Luthi	EM101	35773	Aug. 12, 2022	Aug. 11, 2024
Power Meter	R&S	NRVD	8323781027	Mar. 24, 2023	Mar. 23, 2025
Signal Generator	Agilent	E4421B	MY43351603	Feb. 17, 2023	Feb. 16, 2024

Any report having not been signed by authorized approver, or having been altered without authorization, or having not been stamped by the “Dedicated Testing/Inspection Stamp” is deemed to be invalid. Copying or excerpting portion of, or altering the content of the report is not permitted without the written authorization of AGC. The test results presented in the report apply only to the tested sample. Any objections to report issued by AGC should be submitted to AGC within 15days after the issuance of the test report. Further enquiry of validity or verification of the test report should be addressed to AGC by agc01@agccert.com.

7. RADIATED DISTURBANCE MEASUREMENT

7.1. LIMITS OF RADIATED DISTURBANCES

Limits for radiated disturbance 30M to1 GHz at a measurement distance of 3m

Frequency range (MHz)	Quasi peak limits(dBuV/m), for Class B ITE, at 3m measurement distance
30-230	40
230-1000	47

Limits for radiated disturbance above 1 GHz at a measurement distance of 3m

Frequency range (MHz)	Limits (dBuV/m), Class B ITE	
	Peak	Average
1000-3000	70	50
3000-6000	74	54

- Note:** 1. The lower limit shall apply at the transition frequency.
2. Additional provisions may be required for cases where interference occurs.

7.2. TEST PROCEDURE

- (1). The EUT was placed on the top of an insulating table 0.8 meters above the ground at a semi-anechoic chamber. The table was rotated 360 degrees to determine the position of the highest radiation.
- (2). The EUT was set 3 meters away from the interference-receiving antenna, which was mounted on the top of a variable-height antenna tower.
- (3).The antenna is a broadband antenna, and its height is varied from 1 to 4 meter above the ground to determine the maximum value of the field strength. Both horizontal and vertical polarizations of the antenna are set to make the measurement.
- (4). For each suspected emission, the EUT was arranged to its worst case and then the antenna was tuned to the heights from 1 to 4 meters and the rotatable table was turned from 0 degrees to 360 degrees to find the maximum reading.
- (5).The test-receiver system was set to Peak Detector Function and Specified Bandwidth with Maximum Hold Mode. If the emission level of the EUT in peak mode was 10dB lower than the limit specified, then testing could be stopped and the peak values of the EUT would be reported. Otherwise the emission that did not have 10dB margin would be retested one by one using the quasi-peak method.

Any report having not been signed by authorized approver, or having been altered without authorization, or having not been stamped by the "Dedicated Testing/Inspection Stamp" is deemed to be invalid. Copying or excerpting portion of, or altering the content of the report is not permitted without the written authorization of AGC. The test results presented in the report apply only to the tested sample. Any objections to report issued by AGC should be submitted to AGC within 15days after the issuance of the test report. Further enquiry of validity or verification of the test report should be addressed to AGC by agc01@agccert.com.

7.3. BLOCK DIAGRAM OF TEST SETUP

Radiated Disturbance below 1 GHz

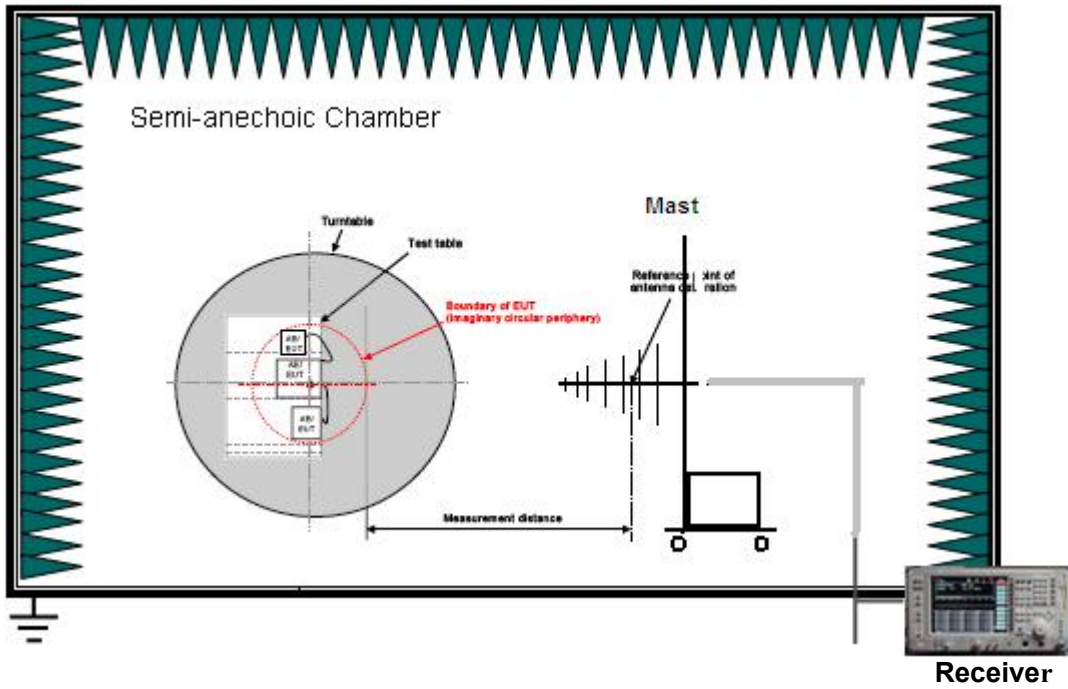

Radiated Disturbance above 1 GHz

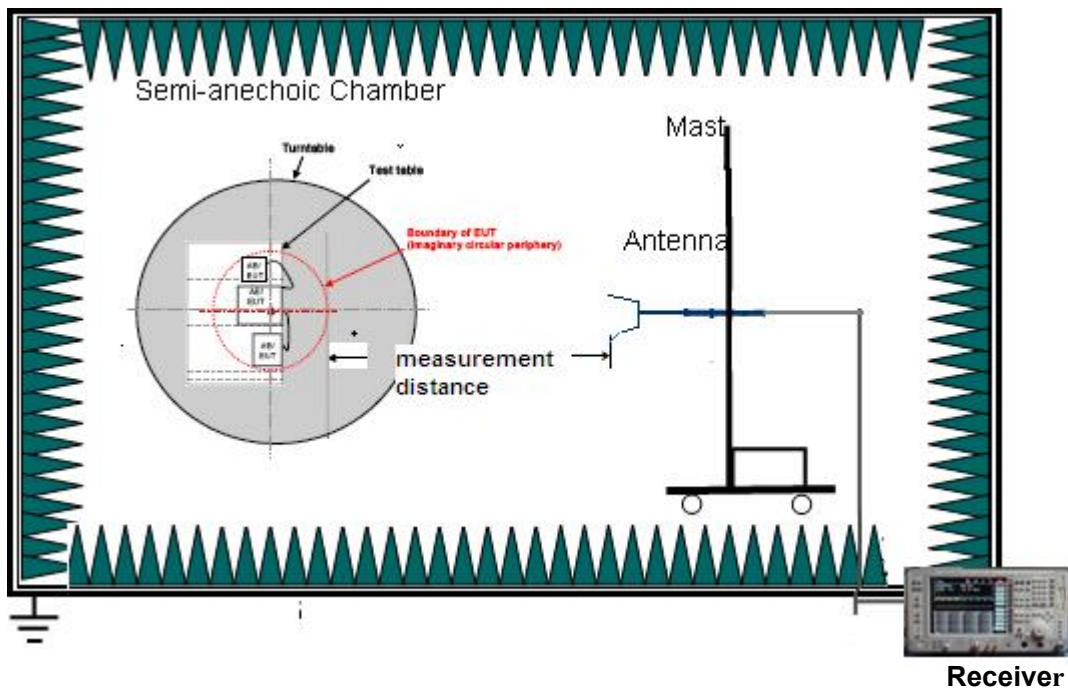

For the actual test configuration, please refer to the related item-Photographs of the Test Configuration.

Any report having not been signed by authorized approver, or having been altered without authorization, or having not been stamped by the “Dedicated Testing/Inspection Stamp” is deemed to be invalid. Copying or excerpting portion of, or altering the content of the report is not permitted without the written authorization of AGC. The test results presented in the report apply only to the tested sample. Any objections to report issued by AGC should be submitted to AGC within 15days after the issuance of the test report. Further enquiry of validity or verification of the test report should be addressed to AGC by agc01@agccert.com.

7.4. TEST RESULT

The test modes were carried out for all modes.

The worst test mode of the EUT was Mode 2, and its test data was showed as the follow:

RADIATED EMISSION BELOW 1GHz– HORIZONTAL

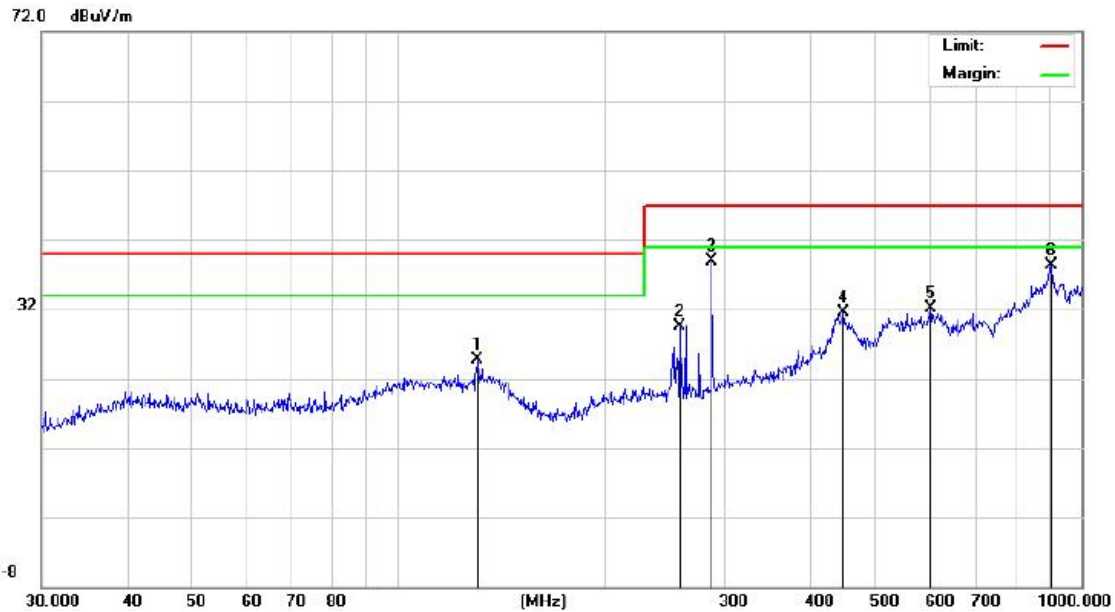

No.	Mk.	Freq. MHz	Reading Level dBuV	Correct Factor dB	Measure- ment dBuV/m	Limit dB/m	Over dB	Detector
1		130.3789	8.89	15.78	24.67	40.00	-15.33	peak
2		258.3264	14.70	14.85	29.55	47.00	-17.45	peak
3	*	287.9904	23.32	15.54	38.86	47.00	-8.14	peak
4		447.9822	6.62	24.82	31.44	47.00	-15.56	peak
5		601.4265	7.03	25.11	32.14	47.00	-14.86	peak
6		903.3094	6.93	31.34	38.27	47.00	-8.73	peak

RESULT: PASS

Any report having not been signed by authorized approver, or having been altered without authorization, or having not been stamped by the “Dedicated Testing/Inspection Stamp” is deemed to be invalid. Copying or excerpting portion of, or altering the content of the report is not permitted without the written authorization of AGC. The test results presented in the report apply only to the tested sample. Any objections to report issued by AGC should be submitted to AGC within 15days after the issuance of the test report. Further enquiry of validity or verification of the test report should be addressed to AGC by agc01@agccert.com.

RADIATED EMISSION BELOW 1GHz- VERTICAL

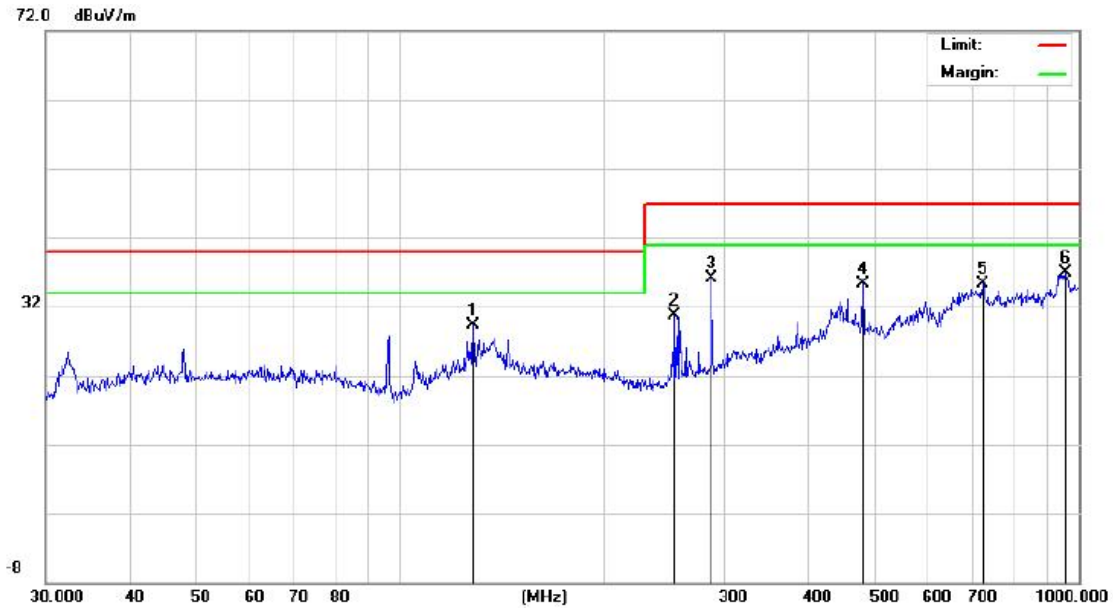

No.	Mk.	Freq. MHz	Reading Level dBuV	Correct Factor dB	Measure- ment dBuV/m	Limit dB/m	Over dB	Detector
1		128.1129	11.35	17.90	29.25	40.00	-10.75	peak
2		253.8367	13.23	17.39	30.62	47.00	-16.38	peak
3		287.9904	17.45	18.60	36.05	47.00	-10.95	peak
4		480.5276	11.46	23.81	35.27	47.00	-11.73	peak
5		721.7259	6.59	28.64	35.23	47.00	-11.77	peak
6	*	955.4380	6.51	30.38	36.89	47.00	-10.11	peak

RESULT: PASS

Any report having not been signed by authorized approver, or having been altered without authorization, or having not been stamped by the "Dedicated Testing/Inspection Stamp" is deemed to be invalid. Copying or excerpting portion of, or altering the content of the report is not permitted without the written authorization of AGC. The test results presented in the report apply only to the tested sample. Any objections to report issued by AGC should be submitted to AGC within 15days after the issuance of the test report. Further enquiry of validity or verification of the test report should be addressed to AGC by agc01@agccert.com.

Attestation of Global Compliance(Shenzhen)Co., Ltd
Attestation of Global Compliance(Shenzhen)Std & Tech Co., Ltd
Tel: +86-755 2523 4088 E-mail: agc@agccert.com Web: http://www.agccert.com/

RADIATED EMISSION ABOVE 1GHz – HORIZONTAL

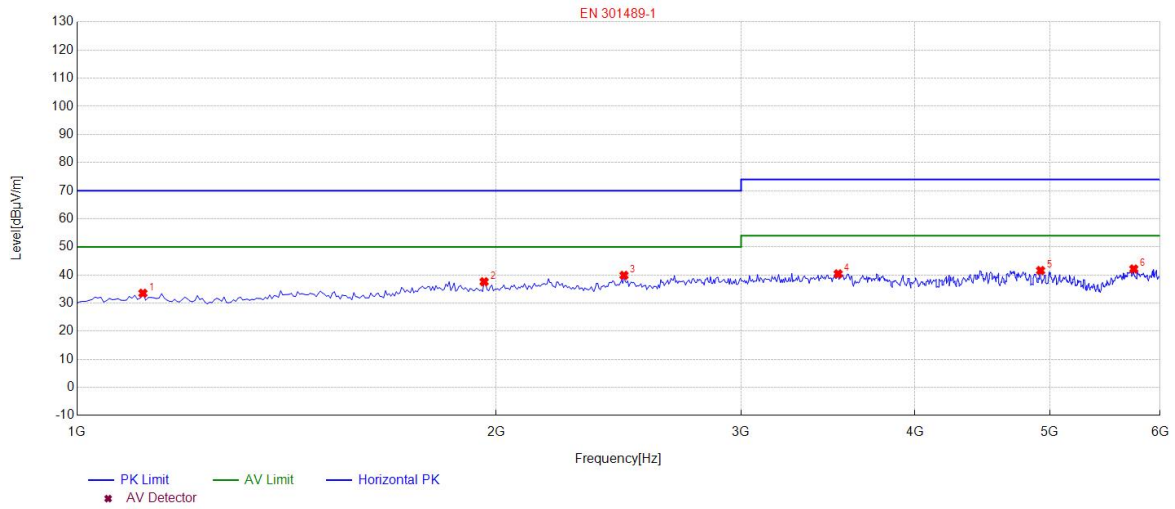

NO.	Freq. [MHz]	Level [dBµV/m]	Factor [dB]	Limit [dBµV/m]	Margin [dB]	Height [cm]	Angle [°]	Polarity
1	1115.1151	33.49	-18.13	70.00	36.51	100	350	Horizontal
2	1960.961	37.58	-13.85	70.00	32.42	100	190	Horizontal
3	2471.4715	39.87	-12.50	70.00	30.13	100	340	Horizontal
4	3522.5225	40.38	-10.80	74.00	33.62	100	120	Horizontal
5	4923.9239	41.57	-7.89	74.00	32.43	100	160	Horizontal
6	5744.7447	42.13	-6.32	74.00	31.87	100	50	Horizontal

RESULT: PASS

Any report having not been signed by authorized approver, or having been altered without authorization, or having not been stamped by the “Dedicated Testing/Inspection Stamp” is deemed to be invalid. Copying or excerpting portion of, or altering the content of the report is not permitted without the written authorization of AGC. The test results presented in the report apply only to the tested sample. Any objections to report issued by AGC should be submitted to AGC within 15days after the issuance of the test report. Further enquiry of validity or verification of the test report should be addressed to AGC by agc01@agccert.com.

RADIATED EMISSION ABOVE 1GHz - VERTICAL

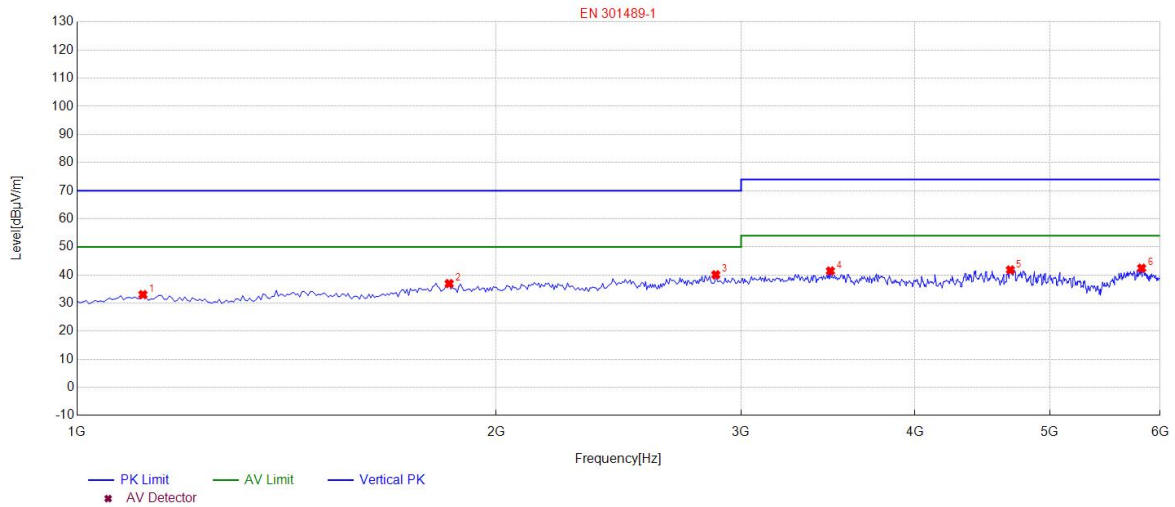

NO.	Freq. [MHz]	Level [dBµV/m]	Factor [dB]	Limit [dBµV/m]	Margin [dB]	Height [cm]	Angle [°]	Polarity
1	1115.1151	33.01	-18.13	70.00	36.99	100	230	Vertical
2	1850.8509	36.92	-14.63	70.00	33.08	100	10	Vertical
3	2876.8769	40.07	-12.14	70.00	29.93	100	280	Vertical
4	3477.4775	41.44	-10.90	74.00	32.56	100	340	Vertical
5	4683.6837	41.79	-7.92	74.00	32.21	100	0	Vertical
6	5819.8198	42.41	-6.13	74.00	31.59	100	280	Vertical

RESULT: PASS

Any report having not been signed by authorized approver, or having been altered without authorization, or having not been stamped by the "Dedicated Testing/Inspection Stamp" is deemed to be invalid. Copying or excerpting portion of, or altering the content of the report is not permitted without the written authorization of AGC. The test results presented in the report apply only to the tested sample. Any objections to report issued by AGC should be submitted to AGC within 15days after the issuance of the test report. Further enquiry of validity or verification of the test report should be addressed to AGC by agc01@agccert.com.

Attestation of Global Compliance(Shenzhen)Co., Ltd
Attestation of Global Compliance(Shenzhen)Std & Tech Co., Ltd
Tel: +86-755 2523 4088 E-mail: agc@agccert.com Web: http://www.agccert.com/

8. CONDUCTED EMISSION MEASUREMENT

8.1. LIMITS OF LINE CONDUCTED EMISSION

Frequency range (MHz)	Limits (dBuV) Class B ITE	
	Quasi-peak	Average
0.15-0.50	66 to 56	56 to 46
0.50-5	56	46
5-30	60	50

Note: 1. The lower limit shall apply at the transition frequencies.

2. The limit decreases linearly with the logarithm of the frequency in the range 0.15MHz to 0.50MHz.

8.2. TEST PROCEDURE

- (1) The equipment was set up as per the test configuration to simulate typical actual usage per the user's manual. When the EUT is a tabletop system, a wooden table with a height of 0.8 meters is used and is placed on the ground plane as per EN 55032 (see Test Facility for the dimensions of the ground plane used). When the EUT is a floor-standing equipment, it is placed on the ground plane which has a 3-12 mm non-conductive covering to insulate the EUT from the ground plane.
- (2) Support equipment, if needed, was placed as per EN 55032.
- (3) All I/O cables were positioned to simulate typical actual usage as per EN 55032.
- (4) The EUT received DC 5V power from adapter which received AC 230V 50Hz power through a Line Impedance Stabilization Network (LISN) which supplied power source and was grounded to the ground plane.
- (5) The EUT test program was started. Emissions were measured on each current carrying line of the EUT using a spectrum Analyzer / Receiver connected to the AN powering the EUT. The AN has two monitoring points: Line 1 (Positive) and Line 2 (Negative). Two scans were taken: one with Line 1 connected to Analyzer / Receiver and Line 2 connected to a 50 ohm load; the second scan had Line 1 connected to a 50 ohm load and Line 2 connected to the Analyzer / Receiver.
- (6) Analyzer / Receiver scanned from 150 kHz to 30 MHz for emissions in each of the test modes.
- (7) During the above scans, the emissions were maximized by cable manipulation.
- (8) A scan was taken on both power lines, Line 1 and Line 2, recording at least the six highest emissions.
- (9) Emission frequency and amplitude were recorded into a computer in which correction factors were used to calculate the emission level and compare reading to the applicable limit. If EUT emission level was less -2dB to the A.V. limit in Peak mode, then the emission signal was re-checked using Q.P and Average detector.

Any report having not been signed by authorized approver, or having been altered without authorization, or having not been stamped by the "Dedicated Testing/Inspection Stamp" is deemed to be invalid. Copying or excerpting portion of, or altering the content of the report is not permitted without the written authorization of AGC. The test results presented in the report apply only to the tested sample. Any objections to report issued by AGC should be submitted to AGC within 15days after the issuance of the test report. Further enquiry of validity or verification of the test report should be addressed to AGC by agc01@agccert.com.

8.3. TEST SETUP

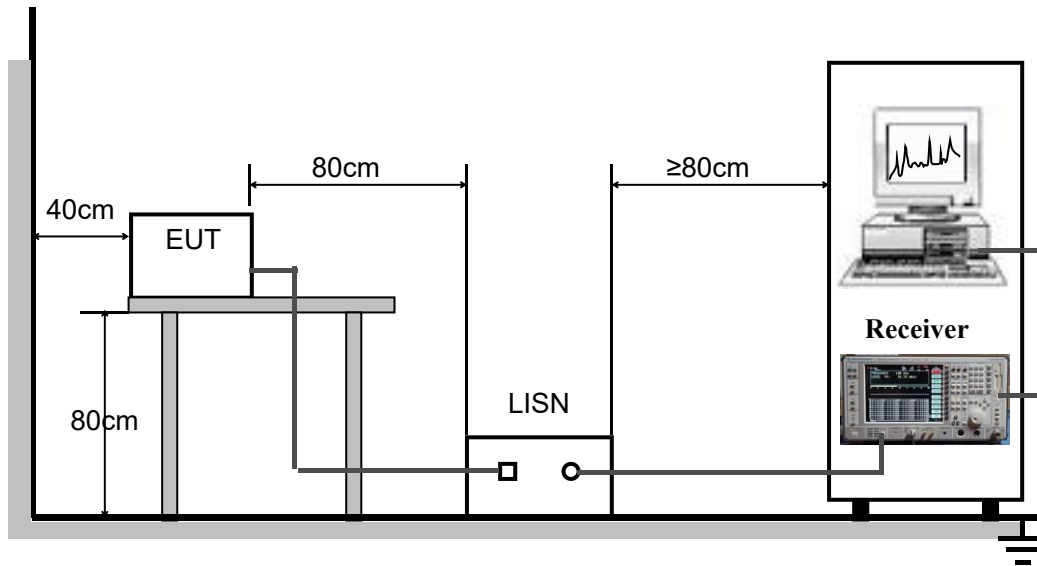

For the actual test configuration, please refer to the related item - Photographs of the Test Configuration.

Any report having not been signed by authorized approver, or having been altered without authorization, or having not been stamped by the "Dedicated Testing/Inspection Stamp" is deemed to be invalid. Copying or excerpting portion of, or altering the content of the report is not permitted without the written authorization of AGC. The test results presented in the report apply only to the tested sample. Any objections to report issued by AGC should be submitted to AGC within 15days after the issuance of the test report. Further enquiry of validity or verification of the test report should be addressed to AGC by agc01@agccert.com.

Attestation of Global Compliance(Shenzhen)Co., Ltd
Attestation of Global Compliance(Shenzhen)Std & Tech Co., Ltd
Tel: +86-755 2523 4088 E-mail: agc@agccert.com Web: <http://www.agccert.com/>

8.4. TEST RESULT

The test modes were carried out for all modes.

The worst test mode of the EUT was Mode 2, and its test data was showed as the follow:

LINE CONDUCTED EMISSION TEST-L

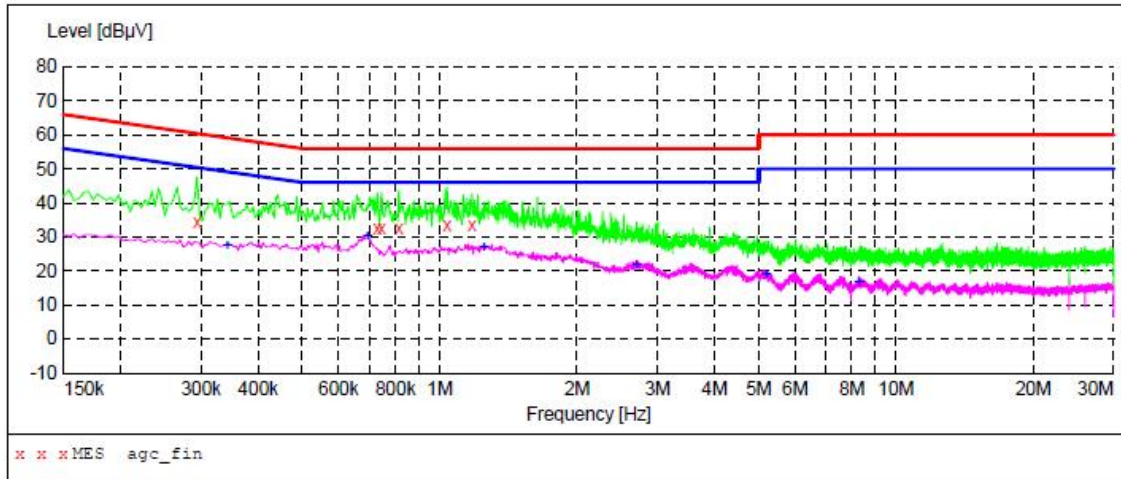

MEASUREMENT RESULT: "agc_fin"

2023/9/27 13:52

Frequency MHz	Level dBµV	Transd dB	Limit dBµV	Margin dB	Detector	Line
0.294000	34.50	6.1	60	25.9	QP	L1
0.730000	32.50	6.2	56	23.5	QP	L1
0.746000	32.40	6.2	56	23.6	QP	L1
0.814000	32.50	6.2	56	23.5	QP	L1
1.038000	33.50	6.2	56	22.5	QP	L1
1.178000	33.50	6.2	56	22.5	QP	L1

MEASUREMENT RESULT: "agc_fin2"

2023/9/27 13:52

Frequency MHz	Level dBµV	Transd dB	Limit dBµV	Margin dB	Detector	Line
0.342000	27.50	6.1	49	21.7	AV	L1
0.694000	30.00	6.2	46	16.0	AV	L1
1.250000	27.00	6.2	46	19.0	AV	L1
2.698000	21.60	6.3	46	24.4	AV	L1
5.194000	18.80	6.4	50	31.2	AV	L1
8.282000	16.50	6.6	50	33.5	AV	L1

RESULT: PASS

Any report having not been signed by authorized approver, or having been altered without authorization, or having not been stamped by the "Dedicated Testing/Inspection Stamp" is deemed to be invalid. Copying or excerpting portion of, or altering the content of the report is not permitted without the written authorization of AGC. The test results presented in the report apply only to the tested sample. Any objections to report issued by AGC should be submitted to AGC within 15days after the issuance of the test report. Further enquiry of validity or verification of the test report should be addressed to AGC by agc01@agccert.com.

LINE CONDUCTED EMISSION TEST-N

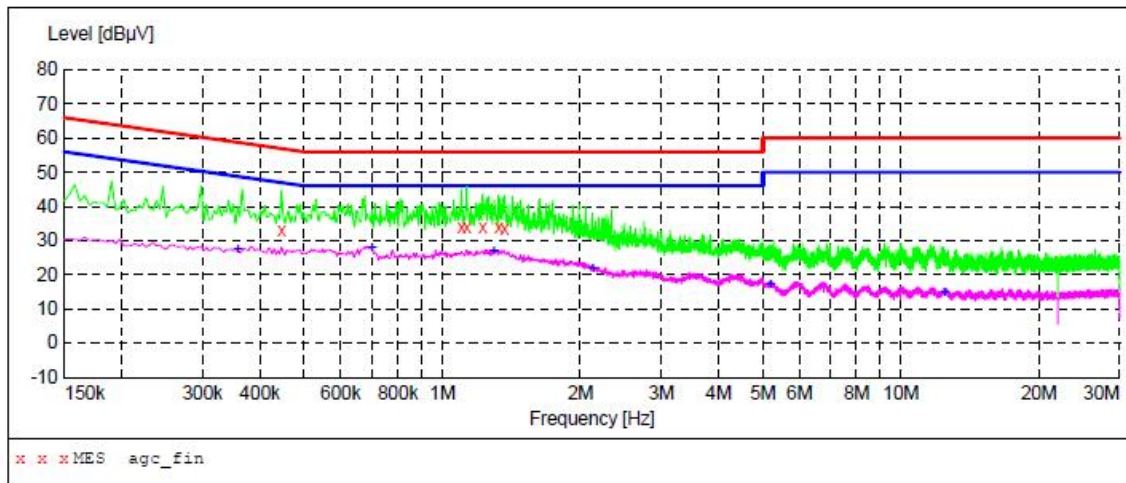

MEASUREMENT RESULT: "agc_fin"

2023/9/27 13:48

Frequency MHz	Level dBµV	Transd dB	Limit dBµV	Margin dB	Detector	Line
0.446000	32.90	6.1	57	24.0	QP	N
1.102000	33.70	6.2	56	22.3	QP	N
1.130000	33.80	6.2	56	22.2	QP	N
1.226000	34.00	6.2	56	22.0	QP	N
1.326000	33.90	6.2	56	22.1	QP	N
1.366000	33.60	6.2	56	22.4	QP	N

MEASUREMENT RESULT: "agc_fin2"

2023/9/27 13:48

Frequency MHz	Level dBµV	Transd dB	Limit dBµV	Margin dB	Detector	Line
0.358000	27.30	6.1	49	21.5	AV	N
0.702000	27.60	6.2	46	18.4	AV	N
1.294000	26.70	6.2	46	19.3	AV	N
2.126000	21.90	6.2	46	24.1	AV	N
5.194000	17.30	6.4	50	32.7	AV	N
12.438000	14.90	6.8	50	35.1	AV	N

RESULT: PASS

Any report having not been signed by authorized approver, or having been altered without authorization, or having not been stamped by the "Dedicated Testing/Inspection Stamp" is deemed to be invalid. Copying or excerpting portion of, or altering the content of the report is not permitted without the written authorization of AGC. The test results presented in the report apply only to the tested sample. Any objections to report issued by AGC should be submitted to AGC within 15days after the issuance of the test report. Further enquiry of validity or verification of the test report should be addressed to AGC by agc01@agccert.com.

9. HARMONIC CURRENT MEASUREMENT

9.1. LIMITS OF HARMONIC CURRENT

Limits for Class A Equipment	
Harmonics Order n	Max. permissible harmonic current (A)
Odd harmonics	
3	2.30
5	1.14
7	0.77
9	0.40
11	0.33
13	0.21
$15 \leq n \leq 39$	$0.15 \times 15/n$
Even harmonics	
2	1.08
4	0.43
6	0.30
$8 \leq n \leq 40$	$0.23 \times 8/n$

Note: 1. According to section 5 of EN 61000-3-2: 2014, the EUT is Class A equipment.
2. The above limits are for all applications having an active input power >75W. No limits apply for equipment with an active input power up to and including 75W.

9.2. TEST PROCEDURE

1. The EUT was placed on the top of a wooden table 0.8 meters above the ground and operated to produce the maximum harmonic components under normal operating conditions for each successive harmonic component in turn.
2. The correspondent test program of test instrument to measure the current harmonics emanated from EUT is chosen. The measure time shall be not less than the necessary for the EUT to be exercised.

9.3. TEST SETUP

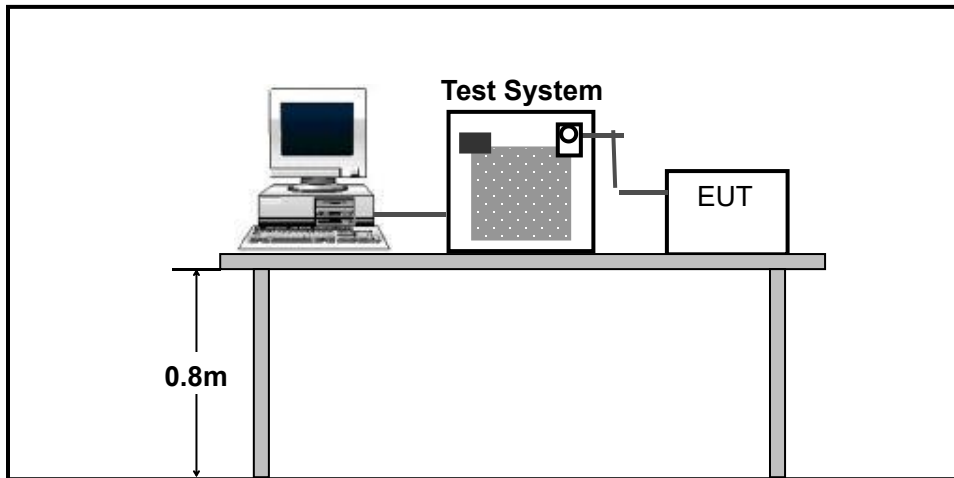

For the actual test configuration, please refer to Appendix A: Photographs of the Test Configuration.

9.4. TEST RESULT

Note: Equipment with a rated power less than or equal to 75W is deemed to fulfil all relevant requirements of this standard without testing.

Any report having not been signed by authorized approver, or having been altered without authorization, or having not been stamped by the “Dedicated Testing/Inspection Stamp” is deemed to be invalid. Copying or excerpting portion of, or altering the content of the report is not permitted without the written authorization of AGC. The test results presented in the report apply only to the tested sample. Any objections to report issued by AGC should be submitted to AGC within 15days after the issuance of the test report. Further enquiry of validity or verification of the test report should be addressed to AGC by agc01@agccert.com.

Attestation of Global Compliance(Shenzhen)Co., Ltd
Attestation of Global Compliance(Shenzhen)Std & Tech Co., Ltd
Tel: +86-755 2523 4088 E-mail: agc@agccert.com Web: <http://www.agccert.com/>

10. VOLTAGE FLUCTUATIONS AND FLICK MEASUREMENT

10.1. LIMITS OF VOLTAGE FLUCTUATIONS AND FLICK

Test Item	Limit	Note
P_{st}	1.0	P_{st} means Short-term flicker indicator
P_{lt}	0.65	P_{lt} means long-term flicker indicator
T_{dt}	0.5	T_{dt} means maximum time that d_t exceeds 3%
$d_{max}(\%)$	4%	d_{max} means maximum relative voltage change.
$d_c(\%)$	3.3%	d_c means relative steady-state voltage change.

10.2. TEST PROCEDURE

1. The EUT was placed on the top of a wooden table 0.8 meters above the ground and operated to produce the most unfavorable sequence of voltage changes under normal conditions
2. During the flick measurement, the measure time shall include that part of whole operation changes. The observation period for short-term flicker indicator is 10 minutes and the observation period for long-term flicker indicator is 2 hours.

10.3. TEST SETUP

Same as 9.3

10.4. TEST RESULT

Test Specification

Test Frequency	50Hz	Test Voltage	230V AC
Waveform	Sine	Test Time	10 minutes(P_{st}); 2 hours (P_{lt})

Test Result

Test Parameter	Measurement Value	Limit	Remarks
P_{st}	0.261	1.0	Pass
P_{lt}	0.114	0.65	Pass
$T_{dt(s)}$	0.0	0.5	Pass
$d_{max}(\%)$	0.00	4%	Pass
$d_c(\%)$	0.00	3.3%	Pass

Any report having not been signed by authorized approver, or having been altered without authorization, or having not been stamped by the "Dedicated Testing/Inspection Stamp" is deemed to be invalid. Copying or excerpting portion of, or altering the content of the report is not permitted without the written authorization of AGC. The test results presented in the report apply only to the tested sample. Any objections to report issued by AGC should be submitted to AGC within 15days after the issuance of the test report. Further enquiry of validity or verification of the test report should be addressed to AGC by agc01@agccert.com.

11. IMMUNITY TEST

11.1. DESCRIPTION OF PERFORMANCE CRITERIA

The performance criteria are used to take a decision on whether a radio equipment passes or fails immunity tests.

For the purpose of the present document two categories of performance criteria apply:

- Performance criteria for continuous phenomena.
- Performance criteria for transient phenomena.

11.2. GENERAL PERFORMANCE CRITERIA

1. Performance criteria for continuous phenomena

During the test, the equipment shall:

- continue to operate as intended;
- not unintentionally transmit;
- not unintentionally change its operating state;
- not unintentionally change critical stored data.

2. Performance criteria for transient phenomena

For all ports and transient phenomena with the exception described below, the following applies:

- The application of the transient phenomena shall not result in a change of the mode of operation (e.g. unintended transmission) or the loss of critical stored data.
- After application of the transient phenomena, the equipment shall operate as intended.

For surges applied to symmetrically operated wired network ports intended to be connected directly to outdoor lines the following criteria applies:

- For products with only one symmetrical port intended for connection to outdoor lines, loss of function is allowed, provided the function is self-recoverable, or can be otherwise restored. Information stored in non-volatile memory, or protected by a battery backup, shall not be lost.
- For products with more than one symmetrical port intended for connection to outdoor lines, loss of function on the port under test is allowed, provided the function is self-recoverable. Information stored in non-volatile memory, or protected by a battery backup, shall not be lost.

For a 0 % residual voltage dip tests the following performance criteria apply:

- The performance criteria for transient phenomena shall apply.

For a 70 % residual voltage dip and voltage interruption tests, the following performance criteria apply:

- in the case where the equipment is fitted with or connected to a battery back-up, the performance criteria for transient phenomena shall apply;
- in the case where the equipment is powered solely from the AC mains supply (without the use of a parallel battery back-up) volatile user data may have been lost and if applicable the communication link need not to be maintained and lost functions should be recoverable by user or operator;
- no unintentional responses shall occur at the end of the test, when the voltage is restored to nominal;
- in the event of loss of function(s) or in the event of loss of user stored data, this fact shall be recorded.

3. Performance Table

EN 301 489-17 Performance criteria		
Criteria	During Test	After Test (i.e. as a result of the application of the test)
A	Shall operate as intended. (see note). Shall be no loss of function. Shall be no unintentional transmissions.	Shall operate as intended. Shall be no degradation of performance. Shall be no loss of function. Shall be no loss of critical stored data.
B	May be loss of function.	Functions shall be self-recoverable. Shall operate as intended after recovering. Shall be no loss of critical stored data.
C	May be loss of function.	Functions shall be recoverable by the operator. Shall operate as intended after recovering. Shall be no loss of critical stored data.
<p>The performance criteria A shall apply for continuous phenomena. The performance criteria B shall apply for transient phenomena, except for voltage dips greater than or equal to 100 ms and voltage interruptions of 5 000 ms duration, for which performance criteria C shall apply. Where the EUT is a transmitter in standby mode or receive mode, unintentional transmission shall not occur during the test.</p>		
<p>Note: Operate as intended during the test allows a level of degradation in accordance with the Minimum performance level.</p>		
Minimum performance level		
<p>For equipment that supports a PER or FER, the minimum performance level shall be a PER or FER less than or equal to 10 %. For equipment that does not support a PER or a FER, the minimum performance level shall be no loss of the wireless transmission function needed for the intended use of the equipment.</p>		

Any report having not been signed by authorized approver, or having been altered without authorization, or having not been stamped by the "Dedicated Testing/Inspection Stamp" is deemed to be invalid. Copying or excerpting portion of, or altering the content of the report is not permitted without the written authorization of AGC. The test results presented in the report apply only to the tested sample. Any objections to report issued by AGC should be submitted to AGC within 15days after the issuance of the test report. Further enquiry of validity or verification of the test report should be addressed to AGC by agc01@agccert.com.

12. ELECTROSTATIC DISCHARGE IMMUNITY TEST

12.1 TEST SPECIFICATION

Basic Standard	EN 61000-4-2
Discharge Impedance	330Ω / 150 pF
Discharge Voltage	Air Discharge ±8kV, Contact Discharge ±4kV
Polarity	Positive / Negative
Number of Discharge	Minimum 25 times at each test point
Discharge Mode	Single discharge
Discharge Period	1-second minimum

12.2 TEST PROCEDURE

The test procedure was in accordance with EN 61000-4-2:

- a. Electrostatic discharges were applied only to those points and surfaces of the EUT that are accessible to users during normal operation.
- b. The test was performed with at least ten single discharges on the pre-selected points in the most sensitive polarity.
- c. The time interval between two successive single discharges was at least 1 second.
- d. The ESD generator was held perpendicularly to the surface to which the discharge was applied and the return cable was at least 0.2 meters from the EUT.
- e. Contact discharges were applied to the non-insulating coating, with the pointed tip of the generator penetrating the coating and contacting the conducting substrate.
- f. Air discharges were applied with the round discharge tip of the discharge electrode approaching the EUT as fast as possible (without causing mechanical damage) to touch the EUT. After each discharge, the ESD generator was removed from the EUT and re-triggered for a new single discharge. The test was repeated until all discharges were completed.
- g. At least ten single discharges (in the most sensitive polarity) were applied to the Horizontal Coupling Plane at points on each side of the EUT. The ESD generator was positioned vertically at a distance of 0.1 meters from the EUT with the discharge electrode touching the HCP.
- h. At least ten single discharges (in the most sensitive polarity) were applied to the center of one vertical edge of the Vertical Coupling Plane in sufficiently different positions that the four faces of the EUT were completely illuminated. The VCP (dimensions 0.5m×0.5m) was placed vertically to and 0.1 meters from the EUT.

Any report having not been signed by authorized approver, or having been altered without authorization, or having not been stamped by the "Dedicated Testing/Inspection Stamp" is deemed to be invalid. Copying or excerpting portion of, or altering the content of the report is not permitted without the written authorization of AGC. The test results presented in the report apply only to the tested sample. Any objections to report issued by AGC should be submitted to AGC within 15days after the issuance of the test report. Further enquiry of validity or verification of the test report should be addressed to AGC by agc01@agccert.com.

12.3 TEST SETUP

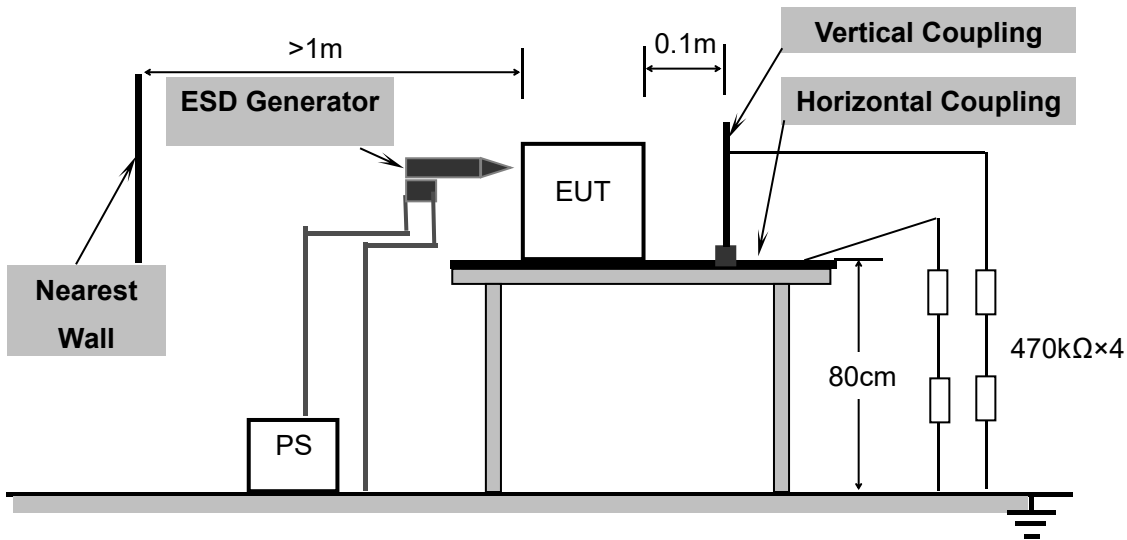

For the actual test configuration, please refer to Appendix A: Photographs of the Test Configuration.

Any report having not been signed by authorized approver, or having been altered without authorization, or having not been stamped by the “Dedicated Testing/Inspection Stamp” is deemed to be invalid. Copying or excerpting portion of, or altering the content of the report is not permitted without the written authorization of AGC. The test results presented in the report apply only to the tested sample. Any objections to report issued by AGC should be submitted to AGC within 15days after the issuance of the test report. Further enquiry of validity or verification of the test report should be addressed to AGC by agc01@agccert.com.

ESD LOCATION:

Blue line: Air discharge

Red line: Contact discharge



Any report having not been signed by authorized approver, or having been altered without authorization, or having not been stamped by the “Dedicated Testing/Inspection Stamp” is deemed to be invalid. Copying or excerpting portion of, or altering the content of the report is not permitted without the written authorization of AGC. The test results presented in the report apply only to the tested sample. Any objections to report issued by AGC should be submitted to AGC within 15days after the issuance of the test report. Further enquiry of validity or verification of the test report should be addressed to AGC by agc01@agccert.com.

12.4 TEST RESULT

Times of Discharge	Voltage	Coupling	Test Mode	Performance criteria
Mini 25 / Point	±2kV; ±4kV	Contact discharge	Mode 1/2	A
Mini 25 / Point	±2kV; ±4kV; ±8kV	Air Discharge	Mode 1/2	A
Mini 25 / Point	±4kV	Indirect Discharge HCP	Mode 1/2	A
Mini 25 / Point	±4kV	Indirect Discharge VCP	Mode 1/2	A

A: No degradation in the performance of the EUT was observed.

Note: operating mode include all modes of EMS in page 9.

12.5 PERFORMANCE

<input checked="" type="checkbox"/> Criteria A:	The apparatus continues to operate as intended. No degradation of performance or loss of function is allowed below a performance level specified by the manufacturer, when the apparatus is used as intended. In some cases the performance level may be replaced by a permissible loss of performance.
<input type="checkbox"/> Criteria B:	The apparatus continues to operate as intended after the test. No degradation of performance or loss of function is allowed below a performance level specified by the manufacturer, when the apparatus is used as intended. In some cases the performance level may be replaced by a permissible loss of performance. During the test, degradation of performance is however allowed.
<input type="checkbox"/> Criteria C:	Temporary loss of function is allowed, provided the functions self recoverable or can be restored by the operation of controls.

Compliance **Not Compliance**

Any report having not been signed by authorized approver, or having been altered without authorization, or having not been stamped by the “Dedicated Testing/Inspection Stamp” is deemed to be invalid. Copying or excerpting portion of, or altering the content of the report is not permitted without the written authorization of AGC. The test results presented in the report apply only to the tested sample. Any objections to report issued by AGC should be submitted to AGC within 15days after the issuance of the test report. Further enquiry of validity or verification of the test report should be addressed to AGC by agc01@agccert.com.

13. RADIATED, RADIO FREQUENCY ELECTROMAGNETIC FIELD IMMUNITY TEST

13.1. TEST SPECIFICATION

Basic Standard	EN 61000-4-3
Frequency Range	80 MHz – 6000MHzMHz
Field Strength	3V/m
Modulation	1 kHz sine wave, 80%, AM modulation
Frequency Step	1% of fundamental
Polarity of Antenna	Horizontal and Vertical
Test Distance	3m
Antenna Height	1.55m
Dwell Time	3 seconds

13.2. TEST PROCEDURE

The test procedure was in accordance with EN 61000-4-3.

- a. The testing was performed in a fully anechoic chamber. The transmit antenna was located at a distance of 3 meters from the EUT.
- b. The test signal was 80% amplitude modulated with a 1 kHz sine wave.
- c. The frequency range was swept from 80 MHz to 6000MHz with the exception of the exclusion band for transmitters, receivers and duplex transceivers. The rate of sweep did not exceed 1.5×10^{-3} decade/s. Where the frequency range is swept incrementally, the step size was 1% of fundamental.
- d. The dwell time at each frequency shall be not less than the time necessary for the EUT to be able to respond.
- e. The field strength level was 3V/m.
- f. The test was performed with the EUT exposed to both vertically and horizontally polarized fields on each of the four sides.

Any report having not been signed by authorized approver, or having been altered without authorization, or having not been stamped by the "Dedicated Testing/Inspection Stamp" is deemed to be invalid. Copying or excerpting portion of, or altering the content of the report is not permitted without the written authorization of AGC. The test results presented in the report apply only to the tested sample. Any objections to report issued by AGC should be submitted to AGC within 15days after the issuance of the test report. Further enquiry of validity or verification of the test report should be addressed to AGC by agc01@agccert.com.

13.3. TEST SETUP

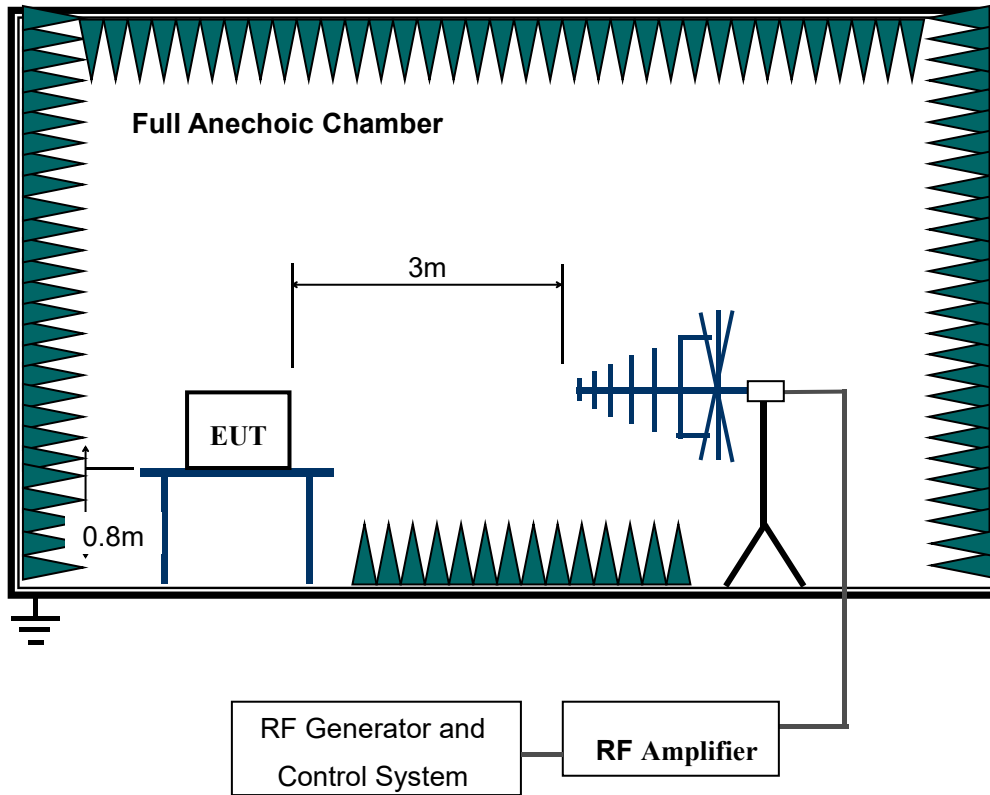

For the actual test configuration, please refer to Appendix A: Photographs of the Test Configuration.

Any report having not been signed by authorized approver, or having been altered without authorization, or having not been stamped by the “Dedicated Testing/Inspection Stamp” is deemed to be invalid. Copying or excerpting portion of, or altering the content of the report is not permitted without the written authorization of AGC. The test results presented in the report apply only to the tested sample. Any objections to report issued by AGC should be submitted to AGC within 15days after the issuance of the test report. Further enquiry of validity or verification of the test report should be addressed to AGC by agc01@agccert.com.

13.4. TEST RESULT

Freq. Range (MHz)	Field	Modulation	Polarity	Position	Test Mode	Performance criteria
80-6000	3V/m	Yes	H	Front	Mode 1/2	A
80-6000	3V/m	Yes	H	Back	Mode 1/2	A
80-6000	3V/m	Yes	H	Left	Mode 1/2	A
80-6000	3V/m	Yes	H	Right	Mode 1/2	A
80-6000	3V/m	Yes	V	Front	Mode 1/2	A
80-6000	3V/m	Yes	V	Back	Mode 1/2	A
80-6000	3V/m	Yes	V	Left	Mode 1/2	A
80-6000	3V/m	Yes	V	Right	Mode 1/2	A

A: No degradation or PER < 10% in the performance of the EUT was observed.

Note: operating mode include all modes of EMS in page 9.

13.5. PERFORMANCE

<input checked="" type="checkbox"/> Criteria A:	The apparatus continues to operate as intended. No degradation of performance or loss of function is allowed below a performance level specified by the manufacturer, when the apparatus is used as intended. In some cases the performance level may be replaced by a permissible loss of performance.
<input type="checkbox"/> Criteria B:	The apparatus continues to operate as intended after the test. No degradation of performance or loss of function is allowed below a performance level specified by the manufacturer, when the apparatus is used as intended. In some cases the performance level may be replaced by a permissible loss of performance. During the test, degradation of performance is however allowed.
<input type="checkbox"/> Criteria C:	Temporary loss of function is allowed, provided the functions self recoverable or can be restored by the operation of controls.

Compliance **Not Compliance**

Any report having not been signed by authorized approver, or having been altered without authorization, or having not been stamped by the "Dedicated Testing/Inspection Stamp" is deemed to be invalid. Copying or excerpting portion of, or altering the content of the report is not permitted without the written authorization of AGC. The test results presented in the report apply only to the tested sample. Any objections to report issued by AGC should be submitted to AGC within 15days after the issuance of the test report. Further enquiry of validity or verification of the test report should be addressed to AGC by agc01@agccert.com.

14. ELECTRICAL FAST TRANSIENT/BURST IMMUNITY TEST

14.1. TEST SPECIFICATION

Basic Standard	EN 61000-4-4
Test Voltage	a.c. power port – 1 kV
Polarity	Positive/Negative
Impulse Frequency	5kHz
Impulse wave shape	5/50ns
Burst Duration	15ms
Burst Period	300ms
Test Duration	Not less than 1 min.

14.2. TEST PROCEDURE

1. The EUT was tested with 1000 volt discharges to the AC power input leads.
2. Both positive and negative polarity discharges were applied.
3. The length of the “hot wire” from the coaxial output of the EFT generator to the terminals on the EUT should not exceed 1 meter.
4. The duration time of each test sequential was 1 minute.
5. The transient/burst waveform was in accordance with IEC 61000-4-4, 5/50ns.

14.3. TEST SETUP

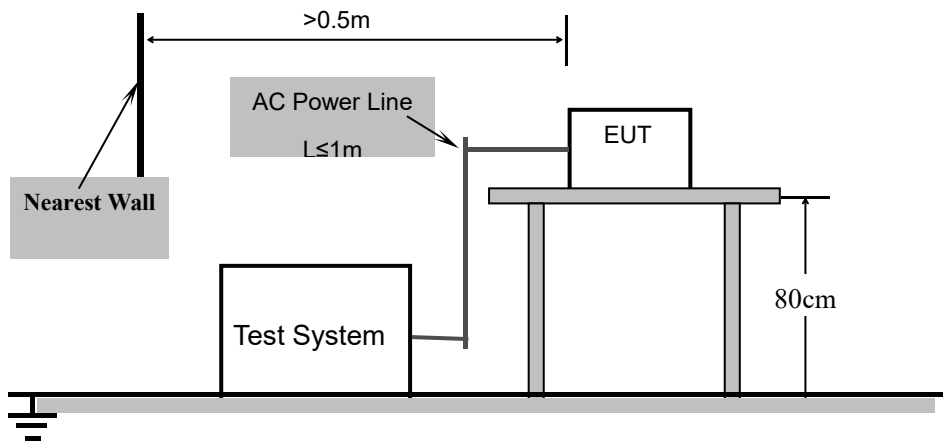

For the actual test configuration, please refer to Appendix A: Photographs of the Test Configuration.

Any report having not been signed by authorized approver, or having been altered without authorization, or having not been stamped by the “Dedicated Testing/Inspection Stamp” is deemed to be invalid. Copying or excerpting portion of, or altering the content of the report is not permitted without the written authorization of AGC. The test results presented in the report apply only to the tested sample. Any objections to report issued by AGC should be submitted to AGC within 15days after the issuance of the test report. Further enquiry of validity or verification of the test report should be addressed to AGC by agc01@agccert.com.

14.4. TEST RESULT

Test Point	Polarity	Test Level (kV)	Test Mode	Performance criteria
a.c. port, L	+/-	1	Mode 2	A
a.c. port, N	+/-	1	Mode 2	A
a.c. port, L-N	+/-	1	Mode 2	A
a.c. port, L-N	+/-	1	Mode 2	A

A: No degradation in the performance of the EUT was observed.

Note: operating mode include all modes of EMS in page 9.

14.5. PERFORMANCE

<input checked="" type="checkbox"/> Criteria A:	The apparatus continues to operate as intended. No degradation of performance or loss of function is allowed below a performance level specified by the manufacturer, when the apparatus is used as intended. In some cases the performance level may be replaced by a permissible loss of performance.
<input type="checkbox"/> Criteria B:	The apparatus continues to operate as intended after the test. No degradation of performance or loss of function is allowed below a performance level specified by the manufacturer, when the apparatus is used as intended. In some cases the performance level may be replaced by a permissible loss of performance. During the test, degradation of performance is however allowed.
<input type="checkbox"/> Criteria C:	Temporary loss of function is allowed, provided the functions self recoverable or can be restored by the operation of controls.

Compliance **Not Compliance**

Any report having not been signed by authorized approver, or having been altered without authorization, or having not been stamped by the "Dedicated Testing/Inspection Stamp" is deemed to be invalid. Copying or excerpting portion of, or altering the content of the report is not permitted without the written authorization of AGC. The test results presented in the report apply only to the tested sample. Any objections to report issued by AGC should be submitted to AGC within 15days after the issuance of the test report. Further enquiry of validity or verification of the test report should be addressed to AGC by agc01@agccert.com.

15. SURGE IMMUNITY TEST

15.1. TEST SPECIFICATION

Basic Standard	EN 61000-4-5
Waveform	Voltage 1.2/50 μ s; Current 8/20 μ s
Test Voltage	a.c. power port, line to line 1.0 kV
Polarity	Positive/Negative
Phase Angle	0°, 90°, 180°, 270°
Repetition Rate	60sec
Times	5 time/each condition.

15.2. TEST PROCEDURE

- The EUT and the auxiliary equipment were placed on a table of 0.8m heights above a metal ground reference plane. The size of ground plane is greater than 1m×1m and project beyond the EUT by at least 0.1m on all sides. The ground plane is connected to the protective earth. The length of power cord between the coupling device and the EUT was less than 2 meters (provided by the manufacturer).
- The EUT was connected to the power mains through a coupling device that directly couples the surge interference signal. The surge noise was applied synchronized to the voltage phase at the zero crossing and the peak value of the AC voltage wave (positive and negative).
- The surges were applied line to line and line(s) to earth. All lower levels including the selected test level were tested. The polarity of each surge level included positive and negative test pulses.

15.3. TEST SETUP

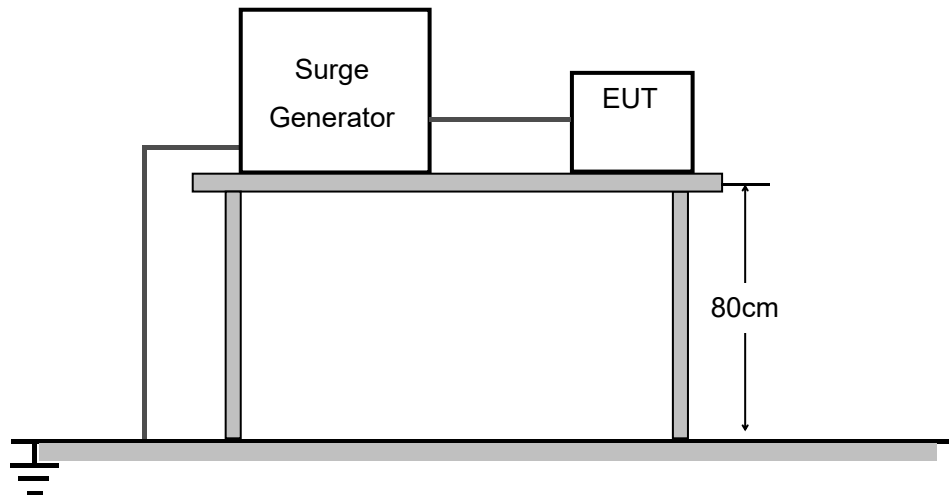

For the actual test configuration, please refer to Appendix A: Photographs of the Test Configuration.

Any report having not been signed by authorized approver, or having been altered without authorization, or having not been stamped by the “Dedicated Testing/Inspection Stamp” is deemed to be invalid. Copying or excerpting portion of, or altering the content of the report is not permitted without the written authorization of AGC. The test results presented in the report apply only to the tested sample. Any objections to report issued by AGC should be submitted to AGC within 15days after the issuance of the test report. Further enquiry of validity or verification of the test report should be addressed to AGC by agc01@agccert.com.

15.4. TEST RESULT

Coupling Line	Polarity	Voltage (kV)	Test Mode	Performance criteria
a.c. power, L-N	+/-	1.0	Mode 2	A

A: No degradation in the performance of the EUT was observed.

Note: operating mode include all modes of EMS in page 9.

15.5. PERFORMANCE

<input checked="" type="checkbox"/> Criteria A:	The apparatus continues to operate as intended. No degradation of performance or loss of function is allowed below a performance level specified by the manufacturer, when the apparatus is used as intended. In some cases the performance level may be replaced by a permissible loss of performance.
<input type="checkbox"/> Criteria B:	The apparatus continues to operate as intended after the test. No degradation of performance or loss of function is allowed below a performance level specified by the manufacturer, when the apparatus is used as intended. In some cases the performance level may be replaced by a permissible loss of performance. During the test, degradation of performance is however allowed.
<input type="checkbox"/> Criteria C:	Temporary loss of function is allowed, provided the functions self recoverable or can be restored by the operation of controls.

Compliance **Not Compliance**

Any report having not been signed by authorized approver, or having been altered without authorization, or having not been stamped by the "Dedicated Testing/Inspection Stamp" is deemed to be invalid. Copying or excerpting portion of, or altering the content of the report is not permitted without the written authorization of AGC. The test results presented in the report apply only to the tested sample. Any objections to report issued by AGC should be submitted to AGC within 15days after the issuance of the test report. Further enquiry of validity or verification of the test report should be addressed to AGC by agc01@agccert.com.

16. IMMUNITY TO CONDUCTED DISTURBANCES INDUCED BY RF FIELDS

16.1. TEST SPECIFICATION

Basic Standard	EN 61000-4-6
Frequency Range	0.15 MHz – 80 MHz
Field Strength	3Vrms
Modulation	1 kHz Sine Wave, 80% AM
Frequency Step	1% of fundamental
Coupled Cable	a.c. power line
Coupling Device	CDN-M2

16.2. TEST PROCEDURE

1. The EUT shall be tested within its intended operating and climatic conditions.
2. The test shall be performed with the test generator connected to each of the coupling and decoupling devices in turn, while the other non-excited RF input ports of the coupling devices are terminated by a 50-ohm load resistor.
3. The test signal was 80% amplitude modulated with a 1 kHz sine wave
4. The frequency range is swept from 150 kHz to 80 MHz, using the signal level established during the setting process and with a disturbance signal of 80% amplitude. The sweep rate shall not exceed 1.5×10^{-3} decades/s. The step size shall not exceed 1% of the start and thereafter 1% of the preceding frequency value where the frequency is swept incrementally.
5. The dwell time at each frequency shall not be less than the time necessary for the EUT to be exercised, and able to respond. Sensitive frequencies such as clock frequencies and harmonics or frequencies of dominant interest, shall be analyzed separately.
6. Attempts should be made to fully exercise the EUT during test, and to fully interrogate all exercise modes selected for susceptibility.

16.3. TEST SETUP

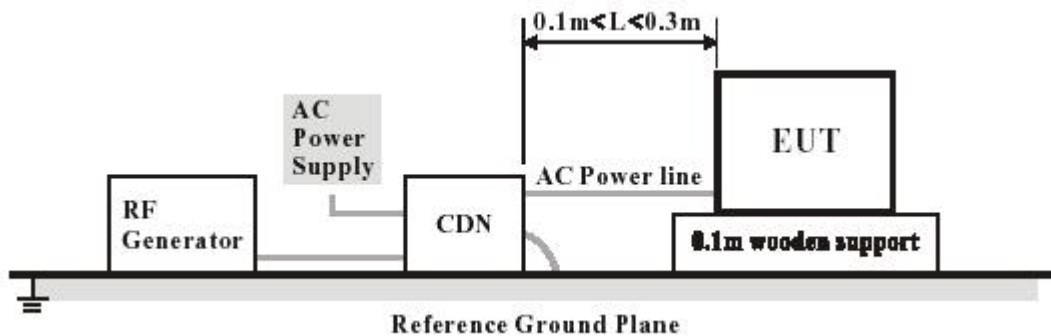

For the actual test configuration, please refer to Appendix A: Photographs of the Test Configuration.

Any report having not been signed by authorized approver, or having been altered without authorization, or having not been stamped by the “Dedicated Testing/Inspection Stamp” is deemed to be invalid. Copying or excerpting portion of, or altering the content of the report is not permitted without the written authorization of AGC. The test results presented in the report apply only to the tested sample. Any objections to report issued by AGC should be submitted to AGC within 15days after the issuance of the test report. Further enquiry of validity or verification of the test report should be addressed to AGC by agc01@agccert.com.

16.4. TEST RESULT

Test Point	Frequency (MHz)	Level (V rms)	Test Mode	Performance criteria
a.c. port	0.15 – 80	3	Mode 2	A

A: No degradation in the performance of the EUT was observed.

Note: operating mode include all modes of EMS in page 9.

16.5. PERFORMANCE

<input checked="" type="checkbox"/> Criteria A:	The apparatus continues to operate as intended. No degradation of performance or loss of function is allowed below a performance level specified by the manufacturer, when the apparatus is used as intended. In some cases the performance level may be replaced by a permissible loss of performance.
<input type="checkbox"/> Criteria B:	The apparatus continues to operate as intended after the test. No degradation of performance or loss of function is allowed below a performance level specified by the manufacturer, when the apparatus is used as intended. In some cases the performance level may be replaced by a permissible loss of performance. During the test, degradation of performance is however allowed.
<input type="checkbox"/> Criteria C:	Temporary loss of function is allowed, provided the functions self recoverable or can be restored by the operation of controls.

<input checked="" type="checkbox"/> Compliance <input type="checkbox"/> Not Compliance
--

Any report having not been signed by authorized approver, or having been altered without authorization, or having not been stamped by the “Dedicated Testing/Inspection Stamp” is deemed to be invalid. Copying or excerpting portion of, or altering the content of the report is not permitted without the written authorization of AGC. The test results presented in the report apply only to the tested sample. Any objections to report issued by AGC should be submitted to AGC within 15days after the issuance of the test report. Further enquiry of validity or verification of the test report should be addressed to AGC by agc01@agccert.com.

17. VOLTAGE DIPS AND SHORT INTERRUPTIONS IMMUNITY TEST

17.1. TEST SPECIFICATION

Basic Standard	EN 61000-4-11
Voltage Dips	100% reduction, 0.5 Cycle 100% reduction, 1.0 Cycle 30% reduction, 25 Cycles
Voltage Interruptions	100% reduction, 250 Cycles
Voltage Phase Angle	0°, 45°, 90°, 135°, 180°, 225°, 270°, 315°

17.2. TEST PROCEDURE

- The power cord was used as supplied by the manufacturer. The EUT was connected to the line output of the Voltage Dips and Interruption Generator.
- The EUT was tested for (1) 100% voltage dip of supplied voltage with duration of 0.5 cycles, (2) 100% voltage dip of supplied voltage and duration 1.0 cycle. (3) 30% voltage dip of supplied voltage and duration 25 cycles. (4) 100% voltage interruption of supplied voltage with duration of 250 Cycles was followed.
- Voltage reductions occur at 0 degree crossover point of the voltage waveform. The performance of the EUT was checked after the voltage dip or interruption.

17.3. TEST SETUP

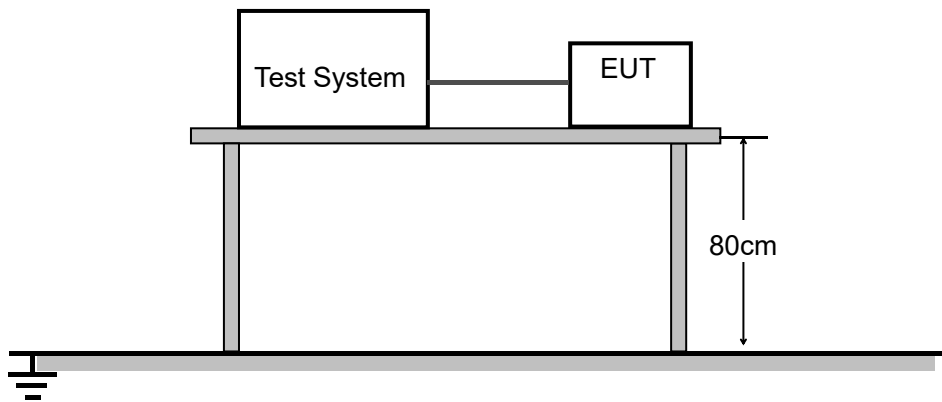

For the actual test configuration, please refer to Appendix A, Photographs of the Test Configuration.

17.4. TEST RESULT

Test Mode	Voltage Reduction	Duration (cycle)	Times	Interval (Sec)	Test Mode	Performance criteria
Voltage dips	100%	0.5	3	10	Mode 2	A
	100%	1	3	10	Mode 2	A
	30%	25	3	10	Mode 2	A
Voltage interruptions	100%	250	3	10	Mode 2	B

A: No degradation in the performance of the EUT was observed.
 B: Stop charging during the test and self-recoverable after test.
 C: Lost functions can be recoverable by user or operator.

Note: operating mode include all modes of EMS in page 9.

17.5. PERFORMANCE

<input checked="" type="checkbox"/> Criteria A:	The apparatus continues to operate as intended. No degradation of performance or loss of function is allowed below a performance level specified by the manufacturer, when the apparatus is used as intended. In some cases the performance level may be replaced by a permissible loss of performance.
<input checked="" type="checkbox"/> Criteria B:	The apparatus continues to operate as intended after the test. No degradation of performance or loss of function is allowed below a performance level specified by the manufacturer, when the apparatus is used as intended. In some cases the performance level may be replaced by a permissible loss of performance. During the test, degradation of performance is however allowed.
<input type="checkbox"/> Criteria C:	Temporary loss of function is allowed, provided the functions self recoverable or can be restored by the operation of controls.

Compliance **Not Compliance**

APPENDIX A: PHOTOGRAPHS OF TEST SETUP

LINE CONDUCTED EMISSION TEST SETUP

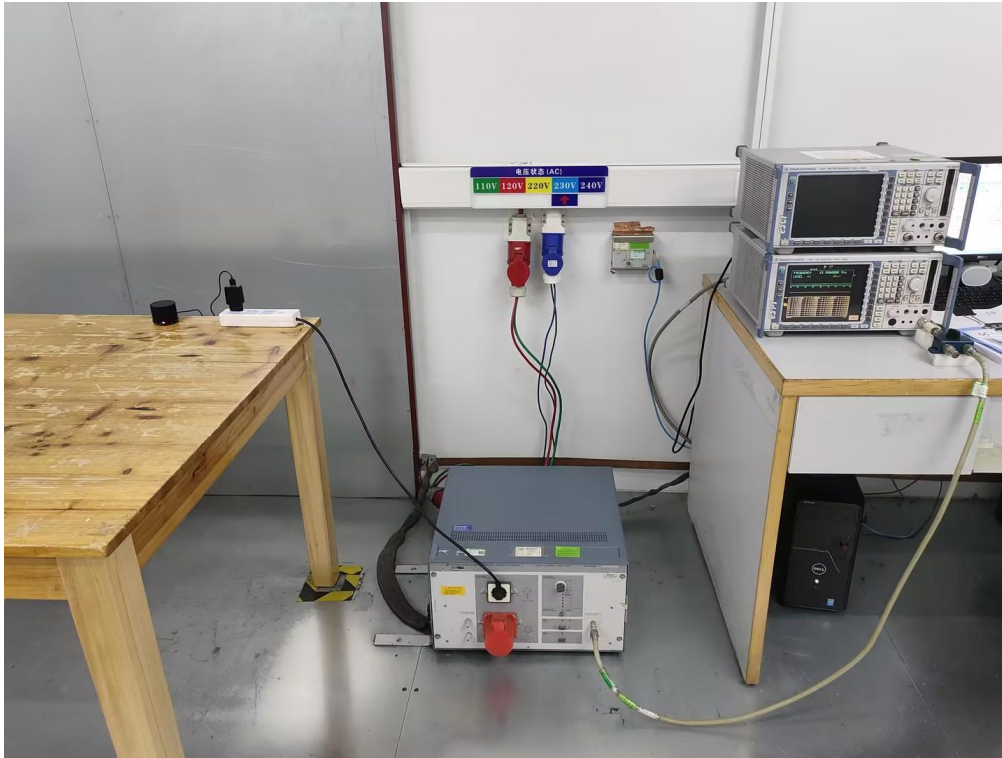

RADIATED EMISSION TEST SETUP BELOW 1GHZ

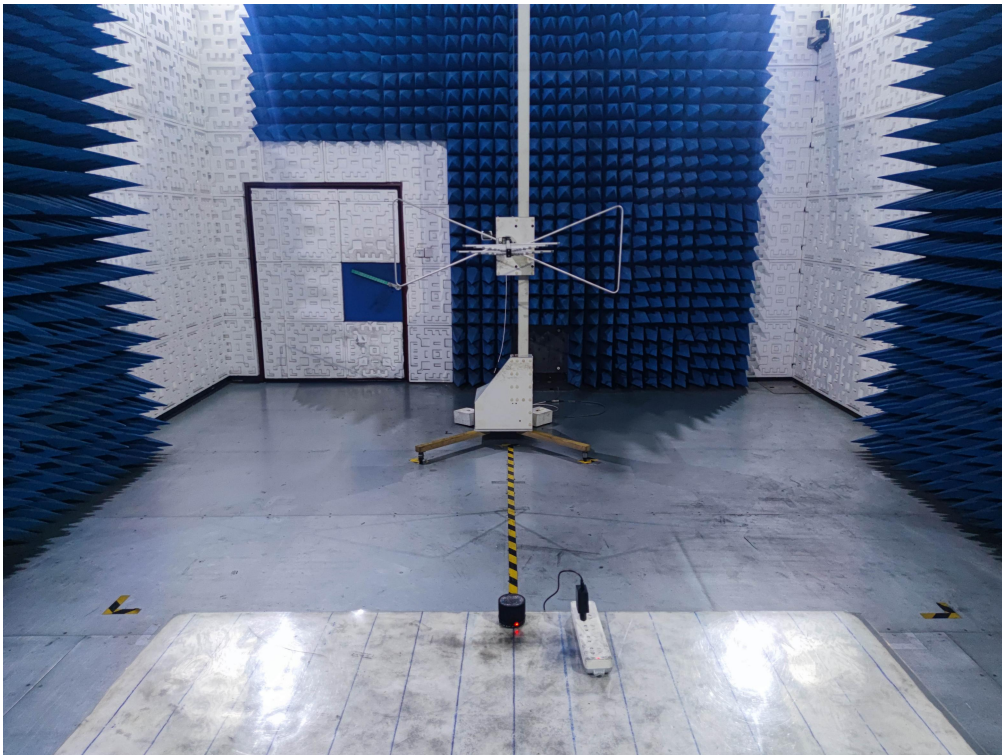

Any report having not been signed by authorized approver, or having been altered without authorization, or having not been stamped by the “Dedicated Testing/Inspection Stamp” is deemed to be invalid. Copying or excerpting portion of, or altering the content of the report is not permitted without the written authorization of AGC. The test results presented in the report apply only to the tested sample. Any objections to report issued by AGC should be submitted to AGC within 15days after the issuance of the test report. Further enquiry of validity or verification of the test report should be addressed to AGC by agc01@agccert.com.

RADIATED EMISSION TEST SETUP ABOVE 1GHZ

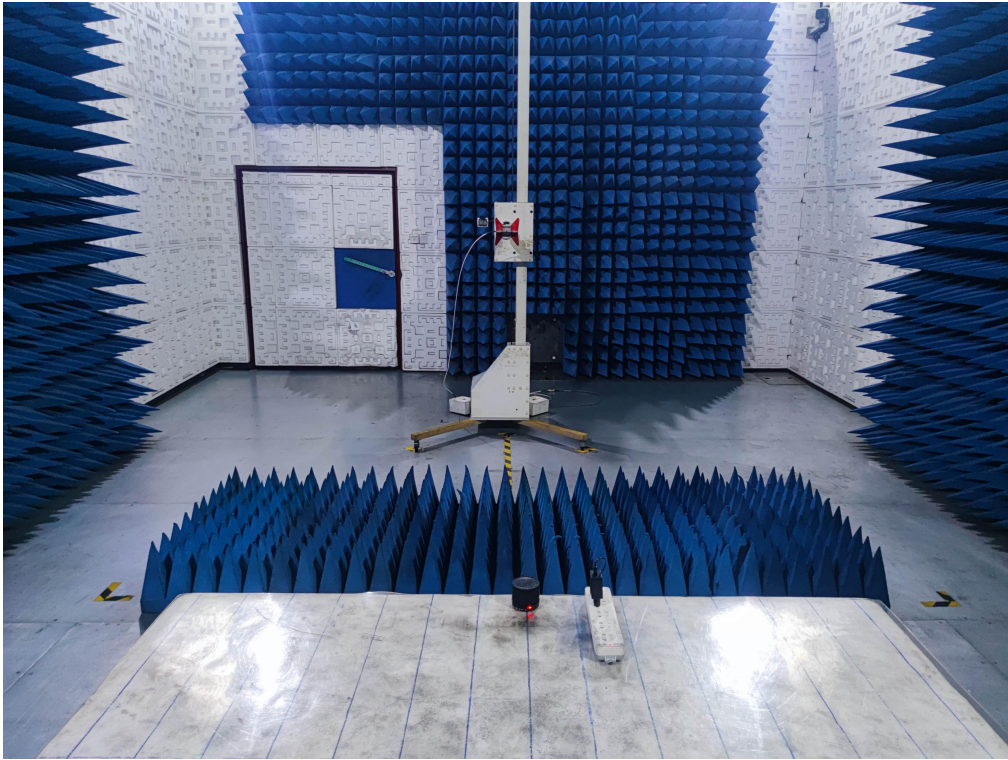

EN 61000-3-3 VOLTAGE FLUCTUATION / FLICKER TEST SETUP



Any report having not been signed by authorized approver, or having been altered without authorization, or having not been stamped by the “Dedicated Testing/Inspection Stamp” is deemed to be invalid. Copying or excerpting portion of, or altering the content of the report is not permitted without the written authorization of AGC. The test results presented in the report apply only to the tested sample. Any objections to report issued by AGC should be submitted to AGC within 15days after the issuance of the test report. Further enquiry of validity or verification of the test report should be addressed to AGC by agc01@agccert.com.

Attestation of Global Compliance(Shenzhen)Co., Ltd
Attestation of Global Compliance(Shenzhen)Std & Tech Co., Ltd
Tel: +86-755 2523 4088 E-mail: agc@agccert.com Web: <http://www.agccert.com/>

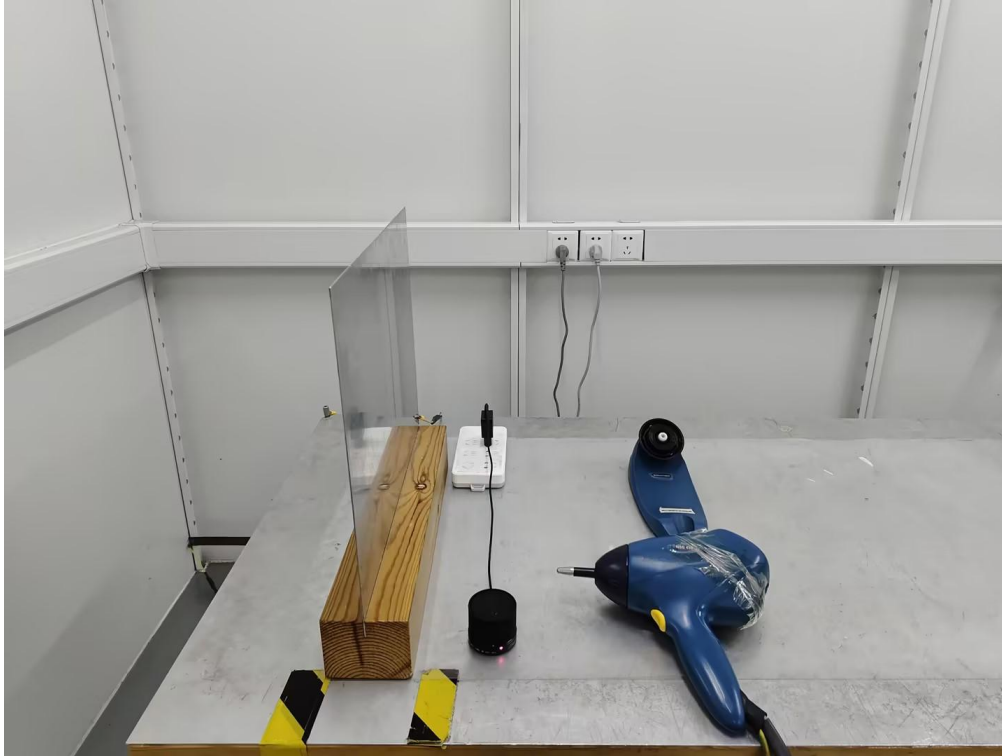
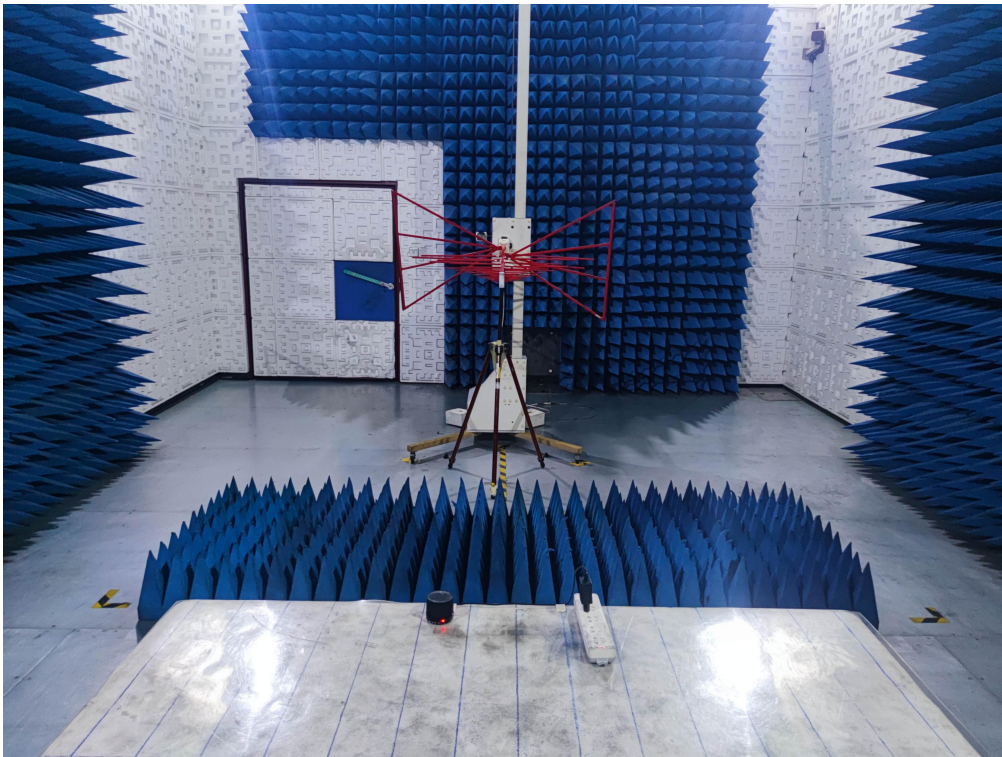
EN 61000-4-2 ESD TEST SETUP**EN 61000-4-3 RS TEST SETUP BELOW 1GHZ**

Any report having not been signed by authorized approver, or having been altered without authorization, or having not been stamped by the “Dedicated Testing/Inspection Stamp” is deemed to be invalid. Copying or excerpting portion of, or altering the content of the report is not permitted without the written authorization of AGC. The test results presented in the report apply only to the tested sample. Any objections to report issued by AGC should be submitted to AGC within 15days after the issuance of the test report. Further enquiry of validity or verification of the test report should be addressed to AGC by agc01@agccert.com.

EN 61000-4-3 RS TEST SETUP ABOVE 1GHZ

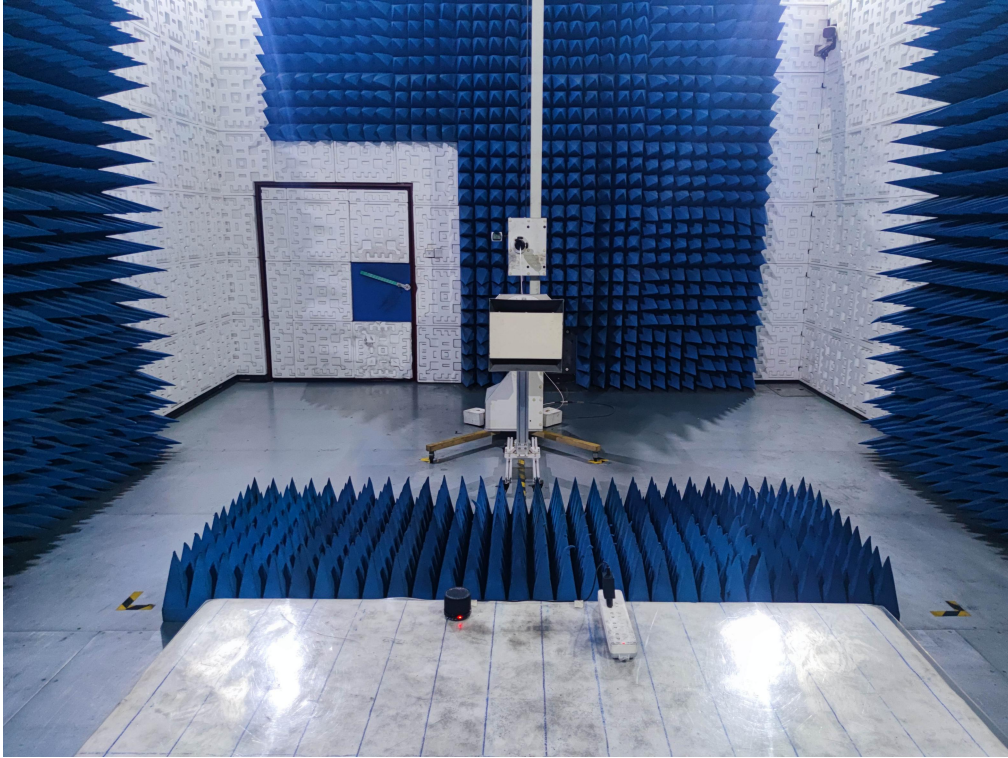

EN 61000-4-4/-5/-11 EFT/SURGE/DIPS IMMUNITY TEST SETUP



Any report having not been signed by authorized approver, or having been altered without authorization, or having not been stamped by the “Dedicated Testing/Inspection Stamp” is deemed to be invalid. Copying or excerpting portion of, or altering the content of the report is not permitted without the written authorization of AGC. The test results presented in the report apply only to the tested sample. Any objections to report issued by AGC should be submitted to AGC within 15days after the issuance of the test report. Further enquiry of validity or verification of the test report should be addressed to AGC by agc01@agccert.com.

EN 61000-4-6 CS IMMUNITY TEST SETUP

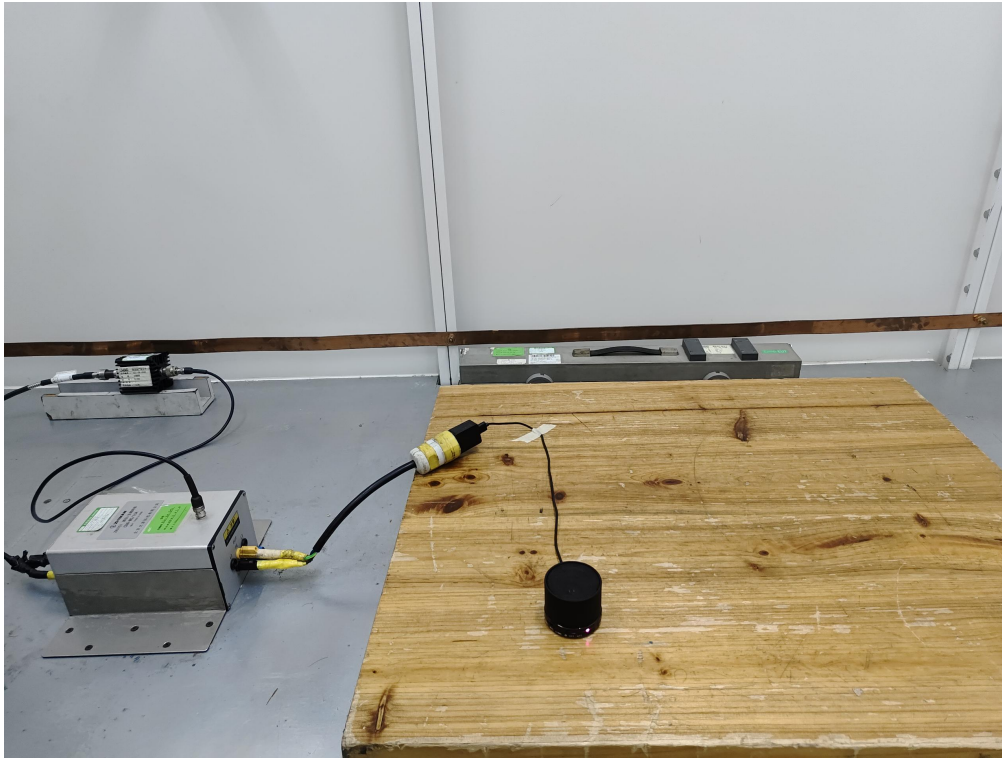

Any report having not been signed by authorized approver, or having been altered without authorization, or having not been stamped by the "Dedicated Testing/Inspection Stamp" is deemed to be invalid. Copying or excerpting portion of, or altering the content of the report is not permitted without the written authorization of AGC. The test results presented in the report apply only to the tested sample. Any objections to report issued by AGC should be submitted to AGC within 15days after the issuance of the test report. Further enquiry of validity or verification of the test report should be addressed to AGC by agc01@agccert.com.

APPENDIX B: PHOTOGRAPHS OF EUT

Refer to the Report No.: AGC12440230905AP01

----END OF REPORT----

Any report having not been signed by authorized approver, or having been altered without authorization, or having not been stamped by the “Dedicated Testing/Inspection Stamp” is deemed to be invalid. Copying or excerpting portion of, or altering the content of the report is not permitted without the written authorization of AGC. The test results presented in the report apply only to the tested sample. Any objections to report issued by AGC should be submitted to AGC within 15days after the issuance of the test report. Further enquiry of validity or verification of the test report should be addressed to AGC by agc01@agccert.com.

Attestation of Global Compliance(Shenzhen)Co., Ltd

Attestation of Global Compliance(Shenzhen)Std & Tech Co., Ltd

Tel: +86-755 2523 4088 E-mail: agc@agccert.com Web: <http://www.agccert.com/>



Conditions of Issuance of Test Reports

1. All samples and goods are accepted by the Attestation of Global Compliance (Shenzhen) Co., Ltd (the “Company”) solely for testing and reporting in accordance with the following terms and conditions. The company provides its services on the basis that such terms and conditions constitute express agreement between the company and any person, firm or company requesting its services (the “Clients”).
2. Any report issued by Company as a result of this application for testing services (the “Report”) shall be issued in confidence to the Clients and the Report will be strictly treated as such by the Company. It may not be reproduced either in its entirety or in part and it may not be used for advertising or other unauthorized purposes without the written consent of the Company. The Clients to whom the Report is issued may, however, show or send it, or a certified copy thereof prepared by the Company to its customer, supplier or other persons directly concerned. The Company will not, without the consent of the Clients, enter into any discussion or correspondence with any third party concerning the contents of the Report, unless required by the relevant governmental authorities, laws or court orders.
3. The Company shall not be called or be liable to be called to give evidence or testimony on the Report in a court of law without its prior written consent, unless required by the relevant governmental authorities, laws or court orders.
4. In the event of the improper use of the report as determined by the Company, the Company reserves the right to withdraw it, and to adopt any other additional remedies which may be appropriate.
5. Samples submitted for testing are accepted on the understanding that the Report issued cannot form the basis of, or be the instrument for, any legal action against the Company.
6. The Company will not be liable for or accept responsibility for any loss or damage however arising from the use of information contained in any of its Reports or in any communication whatsoever about its said tests or investigations.
7. Clients wishing to use the Report in court proceedings or arbitration shall inform the Company to that effect prior to submitting the sample for testing.
8. The Company is not responsible for recalling the electronic version of the original report when any revision is made to them. The Client assumes the responsibility to providing the revised version to any interested party who uses them.
9. Subject to the variable length of retention time for test data and report stored hereinto as otherwise specifically required by individual accreditation authorities, the Company will only keep the supporting test data and information of the test report for a period of six years. The data and information will be disposed of after the aforementioned retention period has elapsed. Under no circumstances shall we provide any data and information which has been disposed of after retention period. Under no circumstances shall we be liable for damage of any kind, including (but not limited to) compensatory damages, lost profits, lost data, or any form of special, incidental, indirect, consequential or punitive damages of any kind, whether based on breach of contract of warranty, tort (including negligence), product liability or otherwise, even if we are informed in advance of the possibility of such damages.

Any report having not been signed by authorized approver, or having been altered without authorization, or having not been stamped by the “Dedicated Testing/Inspection Stamp” is deemed to be invalid. Copying or excerpting portion of, or altering the content of the report is not permitted without the written authorization of AGC. The test results presented in the report apply only to the tested sample. Any objections to report issued by AGC should be submitted to AGC within 15days after the issuance of the test report. Further enquiry of validity or verification of the test report should be addressed to AGC by agc01@agccert.com.

EMC Test Report

Report No.: AGC12440230905EE01

PRODUCT DESIGNATION : Wireless speaker

BRAND NAME : N/A

MODEL NAME : M08726

APPLICANT : Mid Ocean Brands B.V.

DATE OF ISSUE : Oct. 10, 2023

STANDARD(S) : EN 55032: 2015/A11:2020
EN IEC 61000-3-2:2019/A1:2021
EN 61000-3-3:2013/A2:2021
EN 55035:2017/A11:2020

REPORT VERSION : V1.0



Attestation of Global Compliance (Shenzhen) Co., Ltd

Any report having not been signed by authorized approver, or having been altered without authorization, or having not been stamped by the "Dedicated Testing/Inspection Stamp" is deemed to be invalid. Copying or excerpting portion of, or altering the content of the report is not permitted without the written authorization of AGC. The test results presented in the report apply only to the tested sample. Any objections to report issued by AGC should be submitted to AGC within 15days after the issuance of the test report. Further enquiry of validity or verification of the test report should be addressed to AGC by agc01@agccert.com.

Attestation of Global Compliance(Shenzhen)Co., Ltd
Attestation of Global Compliance(Shenzhen)Std & Tech Co., Ltd
Tel: +86-755 2523 4088 E-mail: agc@agccert.com Web: <http://www.agccert.com/>



REPORT REVISE RECORD

Report Version	Revise Time	Issued Date	Valid Version	Notes
V1.0	/	Oct. 10, 2023	Valid	Initial release

Any report having not been signed by authorized approver, or having been altered without authorization, or having not been stamped by the "Dedicated Testing/Inspection Stamp" is deemed to be invalid. Copying or excerpting portion of, or altering the content of the report is not permitted without the written authorization of AGC. The test results presented in the report apply only to the tested sample. Any objections to report issued by AGC should be submitted to AGC within 15days after the issuance of the test report. Further enquiry of validity or verification of the test report should be addressed to AGC by agc01@agccert.com.

Attestation of Global Compliance(Shenzhen)Co., Ltd
Attestation of Global Compliance(Shenzhen)Std & Tech Co., Ltd
Tel: +86-755 2523 4088 E-mail: agc@agccert.com Web: <http://www.agccert.com/>

TABLE OF CONTENTS

1. VERIFICATION OF CONFORMITY 5

2. SYSTEM DESCRIPTION 6

3. MEASUREMENT UNCERTAINTY 7

4. PRODUCT INFORMATION 8

5. SUPPORT EQUIPMENT 9

6. IDENTIFICATION OF THE RESPONSIBLE TESTING LOCATION 10

7. EN 55032 LINE CONDUCTED EMISSION TEST 12

 7.1. LIMITS OF LINE CONDUCTED EMISSION TEST 12

 7.2. BLOCK DIAGRAM OF TEST SETUP 12

 7.3. PROCEDURE OF LINE CONDUCTED EMISSION TEST 13

7.4. TEST RESULT OF LINE CONDUCTED EMISSION TEST 14

8. EN 55032 RADIATED EMISSION TEST 16

 8.1. LIMITS OF RADIATED DISTURBANCES 16

 8.2. BLOCK DIAGRAM OF TEST SETUP 17

 8.3. PROCEDURE OF RADIATED EMISSION TEST 18

 8.4. TEST RESULT OF RADIATED EMISSION TEST 19

9. POWER HARMONICS TEST 23

 9.1. BLOCK DIAGRAM OF TEST SETUP 23

 9.2. RESULT 23

10. VOLTAGE FLUCTUATION / FLICKER TEST 24

 10.1. BLOCK DIAGRAM OF TEST SETUP 24

 10.2. RESULT 25

11. ESD IMMUNITY TEST 26

 11.1. BLOCK DIAGRAM OF TEST SETUP 26

 11.2. TEST PROCEDURE 27

 11.3. PERFORMANCE & RESULT 27

 11.4. PERFORMANCE 29

12. RADIATED, RADIO FREQUENCY ELECTROMAGNETIC FIELD IMMUNITY TEST 30

 12.1. TEST SPECIFICATION 30

Any report having not been signed by authorized approver, or having been altered without authorization, or having not been stamped by the “Dedicated Testing/Inspection Stamp” is deemed to be invalid. Copying or excerpting portion of, or altering the content of the report is not permitted without the written authorization of AGC. The test results presented in the report apply only to the tested sample. Any objections to report issued by AGC should be submitted to AGC within 15days after the issuance of the test report. Further enquiry of validity or verification of the test report should be addressed to AGC by agc01@agccert.com.

12.2. TEST PROCEDURE	30
12.3. TEST SETUP	31
12.4. TEST RESULT	32
12.5. PERFORMANCE	32
13. ELECTRICAL FAST TRANSIENT/BURST IMMUNITY TEST	33
13.1. TEST SPECIFICATION	33
13.2. TEST PROCEDURE	33
13.3. TEST SETUP	33
13.4. TEST RESULT	34
13.5. PERFORMANCE	34
14. SURGE IMMUNITY TEST	35
14.1. TEST SPECIFICATION	35
14.2. TEST PROCEDURE	35
14.3. TEST SETUP	35
14.4. TEST RESULT	36
14.5. PERFORMANCE	36
15. IMMUNITY TO CONDUCTED DISTURBANCES INDUCED BY RF FIELDS	37
15.1. TEST SPECIFICATION	37
15.2. TEST PROCEDURE	37
15.3. TEST SETUP	37
15.4. TEST RESULT	38
15.5. PERFORMANCE	38
16. VOLTAGE DIPS AND SHORT INTERRUPTIONS IMMUNITY TEST	39
16.1. TEST SPECIFICATION	39
16.2. TEST PROCEDURE	39
16.3. TEST SETUP	39
16.4. TEST RESULT	40
16.5. PERFORMANCE	40
APPENDIX A: PHOTOGRAPHS OF TEST SETUP	41
APPENDIX B: PHOTOGRAPHS OF EUT	46

Any report having not been signed by authorized approver, or having been altered without authorization, or having not been stamped by the “Dedicated Testing/Inspection Stamp” is deemed to be invalid. Copying or excerpting portion of, or altering the content of the report is not permitted without the written authorization of AGC. The test results presented in the report apply only to the tested sample. Any objections to report issued by AGC should be submitted to AGC within 15days after the issuance of the test report. Further enquiry of validity or verification of the test report should be addressed to AGC by agc01@agccert.com.

1. VERIFICATION OF CONFORMITY

Applicant	Mid Ocean Brands B.V.
Address	7/F., King Tower, 111King Lam Street, Cheung ShaWan, Kowloon, HongKong.
Manufacturer	Mid Ocean Brands B.V.
Address	7/F., King Tower, 111King Lam Street, Cheung ShaWan, Kowloon, HongKong.
Factory	Mid Ocean Brands B.V.
Address	7/F., King Tower, 111King Lam Street, Cheung ShaWan, Kowloon, HongKong.
Product Designation	Wireless speaker
Brand Name	N/A
Test Model	MO8726
Series Model	N/A
Difference Description	N/A
Date of receipt of test item	Sep. 25, 2023
Date of test	Sep. 25, 2023 to Oct. 09, 2021
Deviation	None
Condition of Test Sample	Normal
Test Result	Pass
Report Template	AGCRT-EC-IT/AC(2013-03-01)

The above equipment was tested by Attestation of Global Compliance (Shenzhen) Co., Ltd. for compliance with the requirements of Technical Standards mentioned above. This said equipment in the configuration described in this report shows the maximum emission levels emanating from equipment. The test results of this report relate only to the tested sample identified in this report.

Prepared By



Sky Zhou
(Project Engineer) Oct. 10, 2023

Reviewed By



Calvin Liu
(Reviewer) Oct. 10, 2023

Approved By



Max Zhang
(Authorized Officer) Oct. 10, 2023

Any report having not been signed by authorized approver, or having been altered without authorization, or having not been stamped by the "Dedicated Testing/Inspection Stamp" is deemed to be invalid. Copying or excerpting portion of, or altering the content of the report is not permitted without the written authorization of AGC. The test results presented in the report apply only to the tested sample. Any objections to report issued by AGC should be submitted to AGC within 15days after the issuance of the test report. Further enquiry of validity or verification of the test report should be addressed to AGC by agc01@agccert.com.

2. SYSTEM DESCRIPTION

TEST MODE DESCRIPTION	
NO.	EMI TEST MODE DESCRIPTION
1	FM mode
2	FM mode with Charging
3	Aux in mode
4	AUX in mode with charging
5	SD card mode
6	SD card mode with charging
NO.	EMS TEST MODE DESCRIPTION
1	FM mode
2	FM mode with Charging
3	Aux in mode
4	AUX in mode with charging
5	SD card mode
6	SD card mode with charging

Any report having not been signed by authorized approver, or having been altered without authorization, or having not been stamped by the "Dedicated Testing/Inspection Stamp" is deemed to be invalid. Copying or excerpting portion of, or altering the content of the report is not permitted without the written authorization of AGC. The test results presented in the report apply only to the tested sample. Any objections to report issued by AGC should be submitted to AGC within 15days after the issuance of the test report. Further enquiry of validity or verification of the test report should be addressed to AGC by agc01@agccert.com.

3. MEASUREMENT UNCERTAINTY

The uncertainty is calculated using the methods suggested in the “Guide to the Expression of Uncertainty in measurement” (GUM) published by ISO.

- Uncertainty of Conducted Emission, $U_c = \pm 2.9$ dB
- Uncertainty of Radiated Emission below 1GHz, $U_c = \pm 3.9$ dB
- Uncertainty of Radiated Emission above 1GHz, $U_c = \pm 4.9$ dB

Any report having not been signed by authorized approver, or having been altered without authorization, or having not been stamped by the “Dedicated Testing/Inspection Stamp” is deemed to be invalid. Copying or excerpting portion of, or altering the content of the report is not permitted without the written authorization of AGC. The test results presented in the report apply only to the tested sample. Any objections to report issued by AGC should be submitted to AGC within 15days after the issuance of the test report. Further enquiry of validity or verification of the test report should be addressed to AGC by agc01@agccert.com.

Attestation of Global Compliance(Shenzhen)Co., Ltd
Attestation of Global Compliance(Shenzhen)Std & Tech Co., Ltd
Tel: +86-755 2523 4088 E-mail: agc@agccert.com Web: <http://www.agccert.com/>

4. PRODUCT INFORMATION

Housing Type	Plastic and metal
Power Supply	DC 3.7V by battery or DC 5V by adapter
Hardware Version	V2.0
Software Version	ac696n_soundbox_sdk_v1.6.0

I/O Port Information (Applicable Not Applicable)

I/O Port of EUT			
I/O Port Type	Number	Cable Description	Tested With
Type-C	1	50cm	1
AUX	1	1m	1

Any report having not been signed by authorized approver, or having been altered without authorization, or having not been stamped by the "Dedicated Testing/Inspection Stamp" is deemed to be invalid. Copying or excerpting portion of, or altering the content of the report is not permitted without the written authorization of AGC. The test results presented in the report apply only to the tested sample. Any objections to report issued by AGC should be submitted to AGC within 15days after the issuance of the test report. Further enquiry of validity or verification of the test report should be addressed to AGC by agc01@agccert.com.

5. SUPPORT EQUIPMENT

Device Type	Manufacturer	Model	Data Cable
iPod	APPLE	MGG82ZP/A	N/A
SD card	Changhong	N/A	N/A
Adapter	jinbaotong	K-T10E0502000E	N/A

Note: 1. "--" means no any support device during testing.

2. All the cables were provided by AGC Lab.

6. IDENTIFICATION OF THE RESPONSIBLE TESTING LOCATION

Site	Attestation of Global Compliance (Shenzhen) Co., Ltd
Location	1-2/F, Building 19, Junfeng Industrial Park, Chongqing Road, Heping Community, Fuhai Street, Bao'an District, Shenzhen, Guangdong, China

TEST EQUIPMENT OF CONDUCTED EMISSION TEST

Equipment	Manufacturer	Model	S/N	Cal. Date	Cal. Due
Test Receiver	R&S	ESPI	101206	Jun. 03, 2023	Jun. 02, 2024
Artificial power network	R&S	ESH2-Z5	100086	Jun. 03, 2023	Jun. 02, 2024
Test software	R&S	ES-K1	Ver.V1.7.1	N/A	N/A

TEST EQUIPMENT OF RADIATED EMISSION TEST

Equipment	Manufacturer	Model	S/N	Cal. Date	Cal. Due
Test Receiver	R&S	ESCI	10096	Feb. 18, 2023	Feb. 17, 2024
Wideband Antenna	SCHWARZBECK	VULB9168	VULB9168-494	Jan. 05, 2023	Jan. 04, 2025
Double-Ridged Waveguide Horn	ETS-LINDGR EN	3117	00034609	Mar. 23, 2023	Mar. 22, 2024
Preamplifier Assembly	ETS	3117PA	00225134	Sep. 02, 2022	Sep. 01, 2024
EXA Signal Analyzer	Aglient	N9010A	MY53470504	Jun. 01, 2023	May 31, 2024
Test Software	FARA	EZ-EMC(Ver.RA-03A)	N/A	N/A	N/A
Test Software	Tonscend	JS32-RE(Ver.2.5)	N/A	N/A	N/A

TEST EQUIPMENT OF POWER HARMONICS / VOLTAGE FLUCTUATION / FLICKER TEST

Equipment	Manufacturer	Model	S/N	Cal. Date	Cal. Due
Signal Conditioning Unit	Schaffner	CCN1000-1	72431	Jun. 08, 2023	Jun. 07, 2024
AC Source	Schaffner	NSG1007	56825	Jun. 02, 2023	Jun. 01, 2024

TEST EQUIPMENT OF ESD TEST

Equipment	Manufacturer	Model	S/N	Cal. Date	Cal. Due
ESD Simulator	Schaffner	NSG 438	782	Dec. 30, 2022	Dec. 29, 2023

Any report having not been signed by authorized approver, or having been altered without authorization, or having not been stamped by the "Dedicated Testing/Inspection Stamp" is deemed to be invalid. Copying or excerpting portion of, or altering the content of the report is not permitted without the written authorization of AGC. The test results presented in the report apply only to the tested sample. Any objections to report issued by AGC should be submitted to AGC within 15days after the issuance of the test report. Further enquiry of validity or verification of the test report should be addressed to AGC by agc01@agccert.com.

TEST EQUIPMENT OF SURGE/EFT/DIPS TEST

Equipment	Manufacturer	Model	S/N	Cal. Date	Cal. Due
EFT/Surge Generator	Schaffner	Modula 6150	34437	Jun. 08, 2023	Jun. 07, 2024

TEST EQUIPMENT OF RS IMMUNITY TEST

Equipment	Manufacturer	Model	S/N	Cal. Date	Cal. Due
Signal Generator	Aglient	N5182A	MY50140530	Feb. 17, 2023	Feb. 16, 2024
Directional coupler	Werlatone	C5571-10	99463	Mar. 10, 2022	Mar. 09, 2024
Directional coupler	Werlatone	C5571-10	99482	Mar. 10, 2022	Mar. 09, 2024
Power Meter	R&S	NRVD	8323781027	Mar. 24, 2022	Mar. 23, 2025
Power Amplifier	KALMUS	7100LC	04-02/17-06-001	N/A	N/A
Power Amplifier	Milmega	AS0104-55_55	1004793	N/A	N/A
Power amplifier	rflight	NTWPA-2560100	17063183	N/A	N/A
Biconilog Antenna	ETS	3142C	00060447	N/A	N/A
Broadband high gain horn antenna	SCHWARZBEC K	BBHA 9120 J	00073	N/A	N/A
Test Software	Tonscend	2.0.1.8	N/A	N/A	N/A

TEST EQUIPMENT OF CS IMMUNITY TEST

Equipment	Manufacturer	Model	S/N	Cal. Date	Cal. Due
Power Amplifier	AR	75A250	18464	N/A	N/A
CDN	ZHINAN	ZN3751	15004	Aug. 03, 2022	Aug. 02, 2024
6dB attenuator	ZHINAN	E-002	N/A	Aug. 04, 2022	Aug. 03, 2024
Power Probe	R&S	URV5-Z4	100124	Mar. 24, 2023	Mar. 23, 2025
Electromagnetic Injection Clamp	Luthi	EM101	35773	Aug. 12, 2022	Aug. 11, 2024
Power Meter	R&S	NRVD	8323781027	Mar. 24, 2023	Mar. 23, 2025
Signal Generator	Aglient	E4421B	MY43351603	Feb. 17, 2023	Feb. 16, 2024

Any report having not been signed by authorized approver, or having been altered without authorization, or having not been stamped by the “Dedicated Testing/Inspection Stamp” is deemed to be invalid. Copying or excerpting portion of, or altering the content of the report is not permitted without the written authorization of AGC. The test results presented in the report apply only to the tested sample. Any objections to report issued by AGC should be submitted to AGC within 15days after the issuance of the test report. Further enquiry of validity or verification of the test report should be addressed to AGC by agc01@agccert.com.

7. EN 55032 LINE CONDUCTED EMISSION TEST

7.1. LIMITS OF LINE CONDUCTED EMISSION TEST

Frequency	Maximum RF Line Voltage	
	Q.P.(dBuV)	Average(dBuV)
150kHz-500kHz	66-56	56-46
500kHz-5MHz	56	46
5MHz-30MHz	60	50

Note: 1. The lower limit shall apply at the transition frequency.

2. The limit decreases linearly with the logarithm of the frequency in the range 0.15 MHz to 0.50MHz.

7.2. BLOCK DIAGRAM OF TEST SETUP

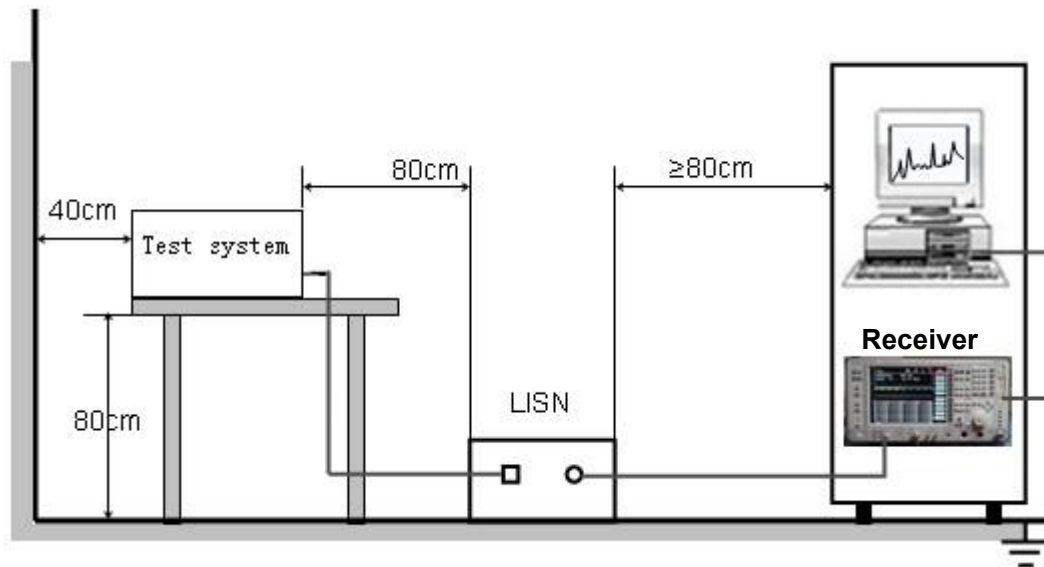

Any report having not been signed by authorized approver, or having been altered without authorization, or having not been stamped by the "Dedicated Testing/Inspection Stamp" is deemed to be invalid. Copying or excerpting portion of, or altering the content of the report is not permitted without the written authorization of AGC. The test results presented in the report apply only to the tested sample. Any objections to report issued by AGC should be submitted to AGC within 15days after the issuance of the test report. Further enquiry of validity or verification of the test report should be addressed to AGC by agc01@agccert.com.

7.3. PROCEDURE OF LINE CONDUCTED EMISSION TEST

- (1) The equipment was set up as per the test configuration to simulate typical actual usage per the user's manual. When the EUT is a tabletop system, a wooden table with a height of 0.8 meters is used and is placed on the ground plane as per EN55032 (see Test Facility for the dimensions of the ground plane used). When the EUT is a floor-standing equipment, it is placed on the ground plane which has a 3-12 mm non-conductive covering to insulate the EUT from the ground plane.
- (2) Support equipment, if needed, was placed as per EN55032.
- (3) All I/O cables were positioned to simulate typical actual usage as per EN55032.
- (4) The EUT received charging voltage by adapter through a Line Impedance Stabilization Network (LISN) which supplied power source and was grounded to the ground plane.
- (5) All support equipments received power from a second LISN supplying power of AC 230V/50Hz, if any.
- (6) The EUT test program was started. Emissions were measured on each current carrying line of the EUT using a spectrum Analyzer / Receiver connected to the LISN powering the EUT. The LISN has two monitoring points: Line 1 (Hot Side) and Line 2 (Neutral Side). Two scans were taken: one with Line 1 connected to Analyzer / Receiver and Line 2 connected to a 50 ohm load; the second scan had Line 1 connected to a 50 ohm load and Line 2 connected to the Analyzer / Receiver.
- (7) Analyzer / Receiver scanned from 150 kHz to 30 MHz for emissions in each of the test modes.
- (8) During the above scans, the emissions were maximized by cable manipulation.
- (9) A scan was taken on both power lines, Line 1 and Line 2, recording at least the six highest emissions.
- (10) Emission frequency and amplitude were recorded into a computer in which correction factors were used to calculate the emission level and compare reading to the applicable limit. If EUT emission level was less -2dB to the A.V. limit in Peak mode, then the emission signal was re-checked using Q.P and Average detector.

Any report having not been signed by authorized approver, or having been altered without authorization, or having not been stamped by the "Dedicated Testing/Inspection Stamp" is deemed to be invalid. Copying or excerpting portion of, or altering the content of the report is not permitted without the written authorization of AGC. The test results presented in the report apply only to the tested sample. Any objections to report issued by AGC should be submitted to AGC within 15days after the issuance of the test report. Further enquiry of validity or verification of the test report should be addressed to AGC by agc01@agccert.com.

7.4. TEST RESULT OF LINE CONDUCTED EMISSION TEST

LINE CONDUCTED EMISSION TEST-L1

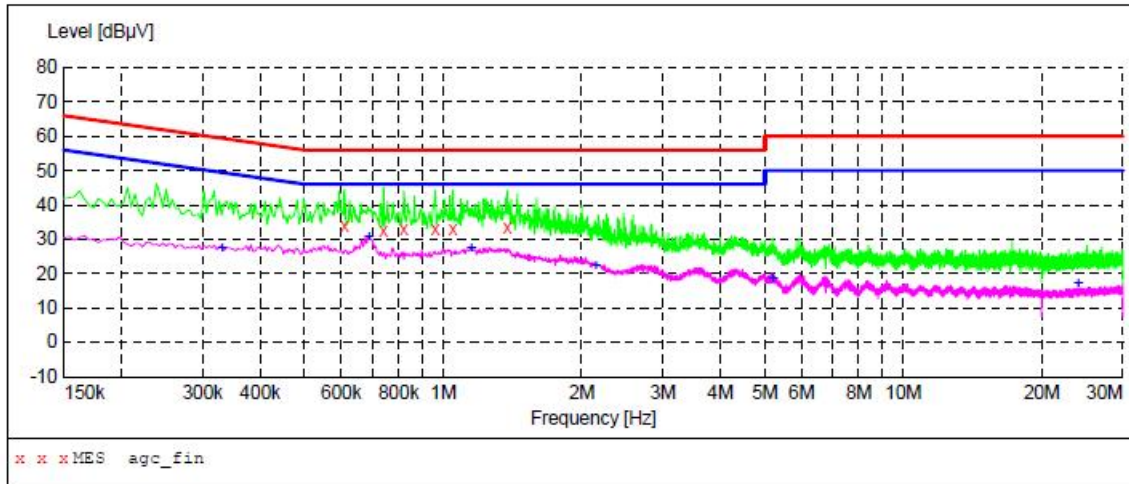

MEASUREMENT RESULT: "agc_fin"

2023/9/27 14:06

Frequency MHz	Level dBµV	Transd dB	Limit dBµV	Margin dB	Detector	Line
0.610000	34.00	6.2	56	22.0	QP	L1
0.742000	32.50	6.2	56	23.5	QP	L1
0.822000	33.20	6.2	56	22.8	QP	L1
0.962000	32.90	6.2	56	23.1	QP	L1
1.050000	33.20	6.2	56	22.8	QP	L1
1.378000	33.30	6.2	56	22.7	QP	L1

MEASUREMENT RESULT: "agc_fin2"

2023/9/27 14:06

Frequency MHz	Level dBµV	Transd dB	Limit dBµV	Margin dB	Detector	Line
0.330000	27.50	6.1	50	22.0	AV	L1
0.690000	30.70	6.2	46	15.3	AV	L1
1.150000	27.20	6.2	46	18.8	AV	L1
2.146000	22.40	6.2	46	23.6	AV	L1
5.190000	18.60	6.4	50	31.4	AV	L1
24.002000	17.20	7.8	50	32.8	AV	L1

RESULT: PASS

Any report having not been signed by authorized approver, or having been altered without authorization, or having not been stamped by the "Dedicated Testing/Inspection Stamp" is deemed to be invalid. Copying or excerpting portion of, or altering the content of the report is not permitted without the written authorization of AGC. The test results presented in the report apply only to the tested sample. Any objections to report issued by AGC should be submitted to AGC within 15days after the issuance of the test report. Further enquiry of validity or verification of the test report should be addressed to AGC by agc01@agccert.com.

LINE CONDUCTED EMISSION TEST-N

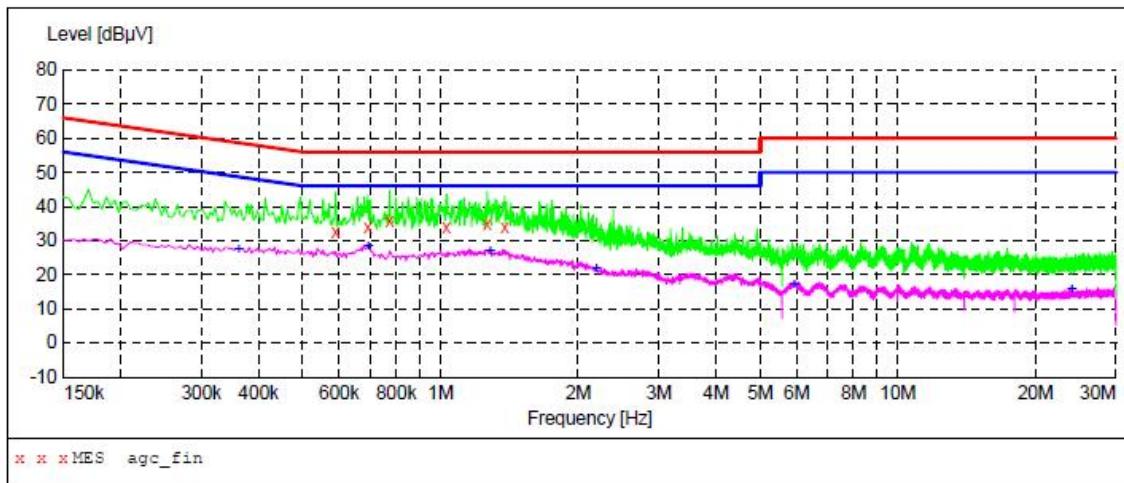

MEASUREMENT RESULT: "agc_fin"

2023/9/27 14:02

Frequency MHz	Level dBµV	Transd dB	Limit dBµV	Margin dB	Detector	Line
0.590000	32.40	6.2	56	23.6	QP	N
0.694000	33.90	6.2	56	22.1	QP	N
0.774000	35.90	6.2	56	20.1	QP	N
1.030000	33.80	6.2	56	22.2	QP	N
1.266000	34.60	6.2	56	21.4	QP	N
1.382000	33.70	6.2	56	22.3	QP	N

MEASUREMENT RESULT: "agc_fin2"

2023/9/27 14:02

Frequency MHz	Level dBµV	Transd dB	Limit dBµV	Margin dB	Detector	Line
0.362000	27.30	6.1	49	21.4	AV	N
0.694000	28.40	6.2	46	17.6	AV	N
1.282000	26.90	6.2	46	19.1	AV	N
2.190000	21.60	6.3	46	24.4	AV	N
5.934000	17.20	6.4	50	32.8	AV	N
24.002000	15.60	7.8	50	34.4	AV	N

RESULT: PASS

Any report having not been signed by authorized approver, or having been altered without authorization, or having not been stamped by the "Dedicated Testing/Inspection Stamp" is deemed to be invalid. Copying or excerpting portion of, or altering the content of the report is not permitted without the written authorization of AGC. The test results presented in the report apply only to the tested sample. Any objections to report issued by AGC should be submitted to AGC within 15days after the issuance of the test report. Further enquiry of validity or verification of the test report should be addressed to AGC by agc01@agccert.com.

8. EN 55032 RADIATED EMISSION TEST

8.1. LIMITS OF RADIATED DISTURBANCES

AT 3M DISTANCES

For class B equipment

Frequency (MHz)	Distance (m)	Maximum Field Strength Limit (dBuV/m Q.P.)
30-230	3	40
230-1000	3	47

For class B equipment

Frequency range (MHz)	Limits (dBuV/m), Class B ITE	
	Peak	Average
1000-3000	70	50
3000-6000	74	54

Note: The lower limit shall apply at the transition frequency.

Any report having not been signed by authorized approver, or having been altered without authorization, or having not been stamped by the "Dedicated Testing/Inspection Stamp" is deemed to be invalid. Copying or excerpting portion of, or altering the content of the report is not permitted without the written authorization of AGC. The test results presented in the report apply only to the tested sample. Any objections to report issued by AGC should be submitted to AGC within 15days after the issuance of the test report. Further enquiry of validity or verification of the test report should be addressed to AGC by agc01@agccert.com.

8.2. BLOCK DIAGRAM OF TEST SETUP

Radiated Disturbance below 1 GHz

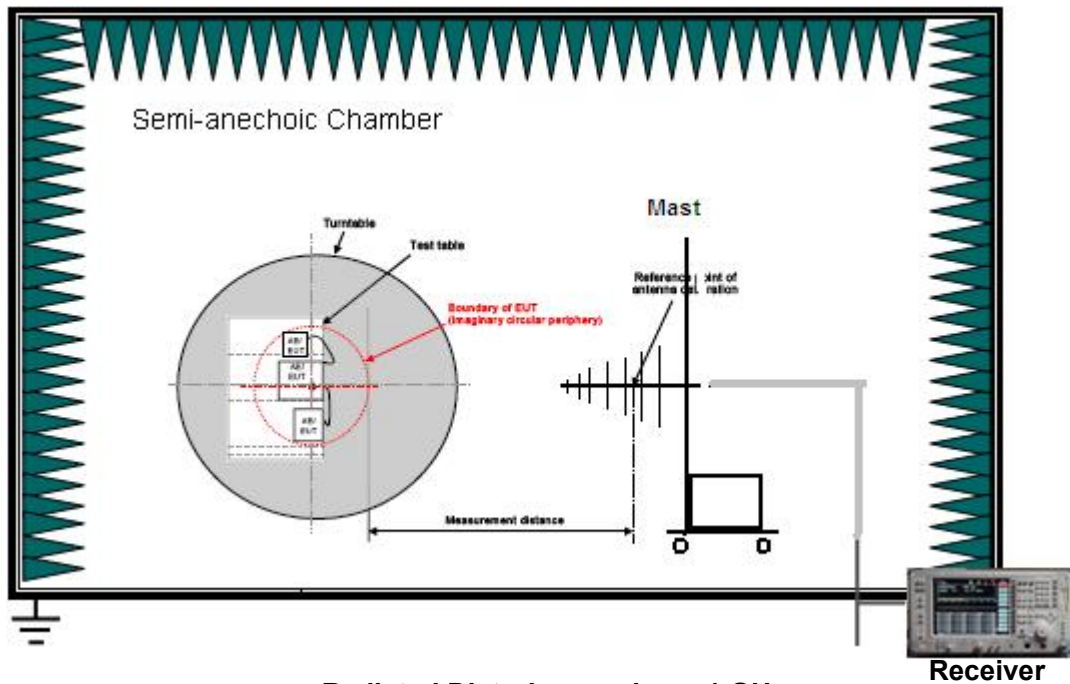

Radiated Disturbance above 1 GHz

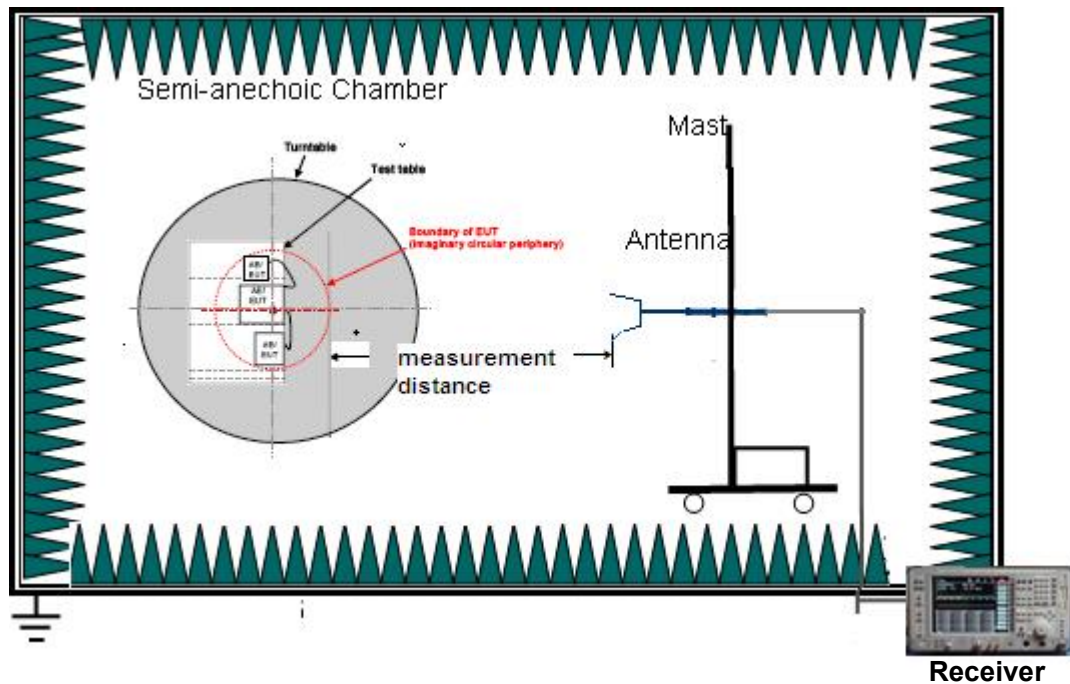

Any report having not been signed by authorized approver, or having been altered without authorization, or having not been stamped by the “Dedicated Testing/Inspection Stamp” is deemed to be invalid. Copying or excerpting portion of, or altering the content of the report is not permitted without the written authorization of AGC. The test results presented in the report apply only to the tested sample. Any objections to report issued by AGC should be submitted to AGC within 15days after the issuance of the test report. Further enquiry of validity or verification of the test report should be addressed to AGC by agc01@agccert.com.

8.3. PROCEDURE OF RADIATED EMISSION TEST

- (1) The equipment was set up as per the test configuration to simulate typical actual usage per the user's manual. When the EUT is a tabletop system, a wooden turntable with a height of 0.8 meters is used which is placed on the ground plane as per EN 55032 (see Test Facility for the dimensions of the ground plane used). When the EUT is a floor-standing equipment, it is placed on the ground plane which has a 3-12 mm non-conductive covering to insulate the EUT from the ground plane.
- (2) Support equipment, if needed, was placed as per EN 55032.
- (3) All I/O cables were positioned to simulate typical actual usage as per EN 55032.
- (4) The EUT received charging voltage by Adapter which got power through the outlet socket under the turntable. All support equipment received AC 230V/50Hz power from socket under the turntable, if any.
- (5) The antenna was placed at 3 meters away from the EUT as stated in EN 55032. The antenna connected to the Analyzer via a cable and at times a pre-amplifier would be used.
- (6) For the test below 1GHz, the Analyzer / Receiver quickly scanned from 30MHz to 1000MHz using 100 kHz RBW and 300 kHz VBW. The EUT test program was started. Emissions were scanned and measured rotating the EUT to 360 degrees and the antenna height scan shall be restricted to a range of 1 m to 4 m above the RGP, in both the vertical and the horizontal polarization, to maximize the emission reading level.
- (7) For the test above 1GHz, the Analyzer / Receiver quickly scanned from 1 GHz to the highest measured frequency using 1 MHz RBW and 3 MHz VBW. The highest measured frequency is defined in Table 1 of CISPR 32. The EUT test program was started. Emissions were scanned and measured rotating the EUT to 360 degrees and the antenna height scan shall encompass those heights defined in Figure 14, Figure 15 and Table 2 of CISPR 16-2-3:2010 AMD1:2010, in both the vertical and the horizontal polarization, to maximize the emission reading level.
- (8) The test mode(s) were scanned during the test:
- (9) Recorded at least the six highest emissions. Emission frequency, amplitude, antenna position, polarization and turntable position were recorded into a computer in which correction factors were used to calculate the emission level and compare reading to the applicable limit. For testing below 1GHz, the emissions level of the EUT in peak mode was lower than Q.P. limit (that means the emissions level in Q.P. mode also complies with the limit in Q.P. mode), then testing will be stopped and peak values of EUT will be reported, otherwise, the emissions will be measured in Q.P. mode again and reported. For testing above 1GHz, the emissions level of the EUT in peak mode was lower than average limit (that means the emissions level in average mode also complies with the limit in average mode), then testing will be stopped and peak values of EUT will be reported, otherwise, the emissions will be measured in average mode again and reported.

Any report having not been signed by authorized approver, or having been altered without authorization, or having not been stamped by the "Dedicated Testing/Inspection Stamp" is deemed to be invalid. Copying or excerpting portion of, or altering the content of the report is not permitted without the written authorization of AGC. The test results presented in the report apply only to the tested sample. Any objections to report issued by AGC should be submitted to AGC within 15days after the issuance of the test report. Further enquiry of validity or verification of the test report should be addressed to AGC by agc01@agccert.com.

8.4. TEST RESULT OF RADIATED EMISSION TEST

RADIATED EMISSION BELOW 1GHZ– HORIZONTAL



No.	Mk.	Freq. MHz	Reading Level dBuV	Correct Factor dB	Measure- ment dBuV/m	Limit dB/m	Over dB	Detector
1		96.0986	9.51	15.60	25.11	40.00	-14.89	peak
2		128.1129	8.84	15.91	24.75	40.00	-15.25	peak
3		256.5210	18.12	14.90	33.02	47.00	-13.98	peak
4		287.9904	21.31	15.54	36.85	47.00	-10.15	peak
5		605.6592	7.25	25.13	32.38	47.00	-14.62	peak
6	*	900.1473	5.36	31.78	37.14	47.00	-9.86	peak

RESULT: PASS

Any report having not been signed by authorized approver, or having been altered without authorization, or having not been stamped by the "Dedicated Testing/Inspection Stamp" is deemed to be invalid. Copying or excerpting portion of, or altering the content of the report is not permitted without the written authorization of AGC. The test results presented in the report apply only to the tested sample. Any objections to report issued by AGC should be submitted to AGC within 15days after the issuance of the test report. Further enquiry of validity or verification of the test report should be addressed to AGC by agc01@agccert.com.

RADIATED EMISSION BELOW 1GHZ- VERTICAL



No.	Mk.	Freq. MHz	Reading Level dBuV	Correct Factor dB	Measure- ment dBuV/m	Limit dB/m	Over dB	Detector
1		128.1130	12.56	17.90	30.46	40.00	-9.54	peak
2		256.5211	15.05	17.61	32.66	47.00	-14.34	peak
3		287.9904	18.17	18.60	36.77	47.00	-10.23	peak
4		480.5276	10.14	23.81	33.95	47.00	-13.05	peak
5		724.2611	6.87	28.40	35.27	47.00	-11.73	peak
6	*	948.7610	7.06	30.65	37.71	47.00	-9.29	peak

RESULT: PASS

Any report having not been signed by authorized approver, or having been altered without authorization, or having not been stamped by the "Dedicated Testing/Inspection Stamp" is deemed to be invalid. Copying or excerpting portion of, or altering the content of the report is not permitted without the written authorization of AGC. The test results presented in the report apply only to the tested sample. Any objections to report issued by AGC should be submitted to AGC within 15days after the issuance of the test report. Further enquiry of validity or verification of the test report should be addressed to AGC by agc01@agccert.com.

RADIATED EMISSION ABOVE 1GHz – HORIZONTAL

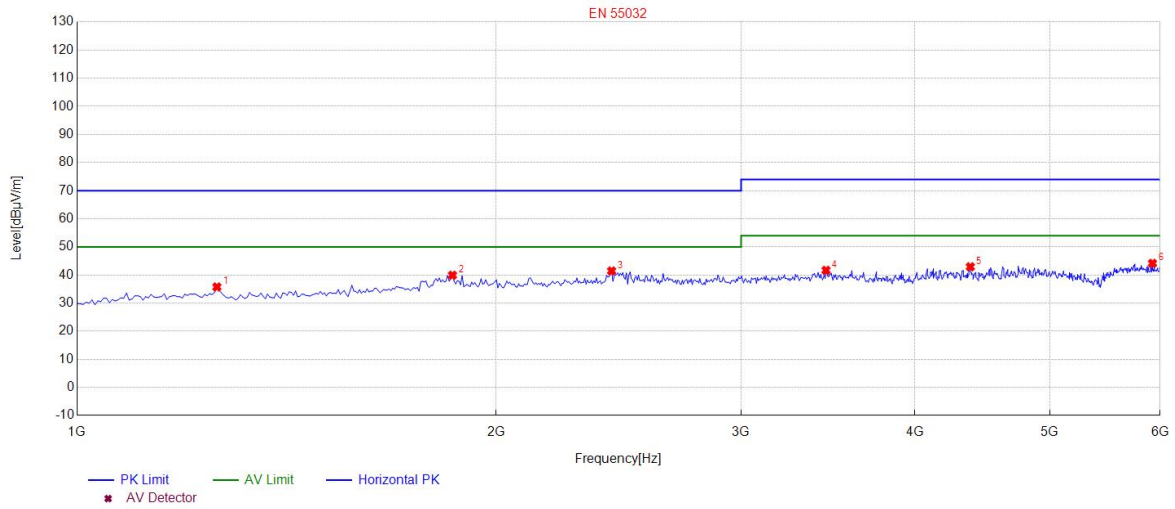

NO.	Freq. [MHz]	Level [dBµV/m]	Factor [dB]	Limit [dBµV/m]	Margin [dB]	Height [cm]	Angle [°]	Polarity
1	1260.2603	35.73	-17.92	70.00	34.27	100	270	Horizontal
2	1860.8609	39.90	-14.56	70.00	30.10	100	350	Horizontal
3	2421.4214	41.43	-12.39	70.00	28.57	100	280	Horizontal
4	3452.4525	41.65	-10.77	74.00	32.35	100	180	Horizontal
5	4383.3834	42.91	-8.37	74.00	31.09	100	220	Horizontal
6	5924.9249	44.14	-5.62	74.00	29.86	100	150	Horizontal

RESULT: PASS

Any report having not been signed by authorized approver, or having been altered without authorization, or having not been stamped by the “Dedicated Testing/Inspection Stamp” is deemed to be invalid. Copying or excerpting portion of, or altering the content of the report is not permitted without the written authorization of AGC. The test results presented in the report apply only to the tested sample. Any objections to report issued by AGC should be submitted to AGC within 15days after the issuance of the test report. Further enquiry of validity or verification of the test report should be addressed to AGC by agc01@agccert.com.

Attestation of Global Compliance(Shenzhen)Co., Ltd
Attestation of Global Compliance(Shenzhen)Std & Tech Co., Ltd
Tel: +86-755 2523 4088 E-mail: agc@agccert.com Web: http://www.agccert.com/

RADIATED EMISSION ABOVE 1GHz - VERTICAL

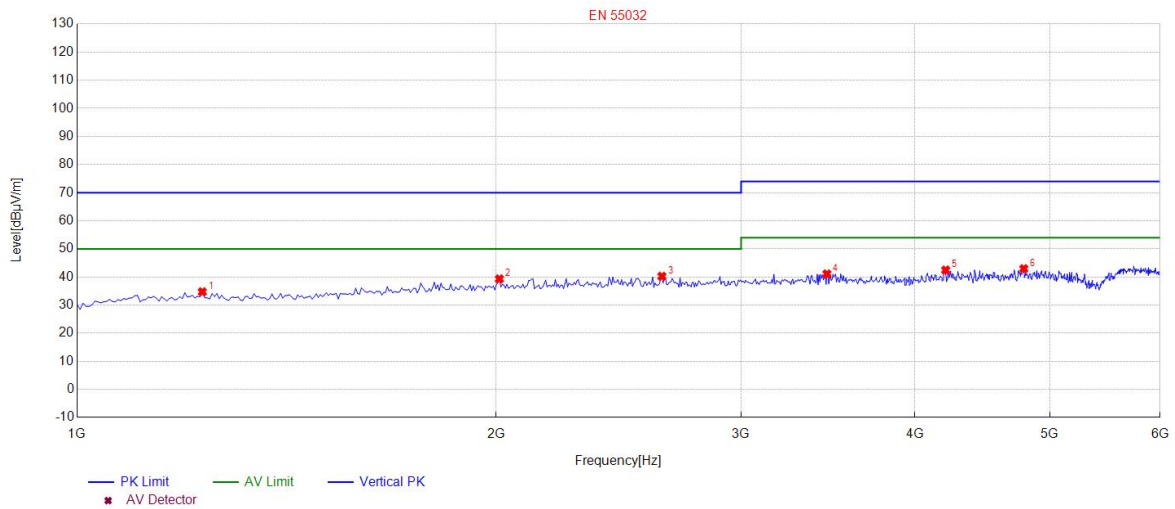

NO.	Freq. [MHz]	Level [dBµV/m]	Factor [dB]	Limit [dBµV/m]	Margin [dB]	Height [cm]	Angle [°]	Polarity
1	1230.2302	34.70	-17.97	70.00	35.30	100	140	Vertical
2	2011.011	39.30	-13.38	70.00	30.70	100	20	Vertical
3	2631.6316	40.24	-12.14	70.00	29.76	100	300	Vertical
4	3457.4575	41.08	-10.75	74.00	32.92	100	200	Vertical
5	4208.2082	42.45	-9.10	74.00	31.55	100	350	Vertical
6	4788.7888	42.93	-7.82	74.00	31.07	100	270	Vertical

RESULT: PASS

Any report having not been signed by authorized approver, or having been altered without authorization, or having not been stamped by the "Dedicated Testing/Inspection Stamp" is deemed to be invalid. Copying or excerpting portion of, or altering the content of the report is not permitted without the written authorization of AGC. The test results presented in the report apply only to the tested sample. Any objections to report issued by AGC should be submitted to AGC within 15days after the issuance of the test report. Further enquiry of validity or verification of the test report should be addressed to AGC by agc01@agccert.com.

Attestation of Global Compliance(Shenzhen)Co., Ltd
Attestation of Global Compliance(Shenzhen)Std & Tech Co., Ltd
Tel: +86-755 2523 4088 E-mail: agc@agccert.com Web: http://www.agccert.com/

9. POWER HARMONICS TEST

Port	AC mains
Basic Standard	EN IEC 61000-3-2
Limits	<input checked="" type="checkbox"/> CLASS A; <input type="checkbox"/> CLASS B; <input type="checkbox"/> CLASS C; <input type="checkbox"/> CLASS D
Temperature	23.9°C
Relative Humidity	62.3%

9.1. BLOCK DIAGRAM OF TEST SETUP

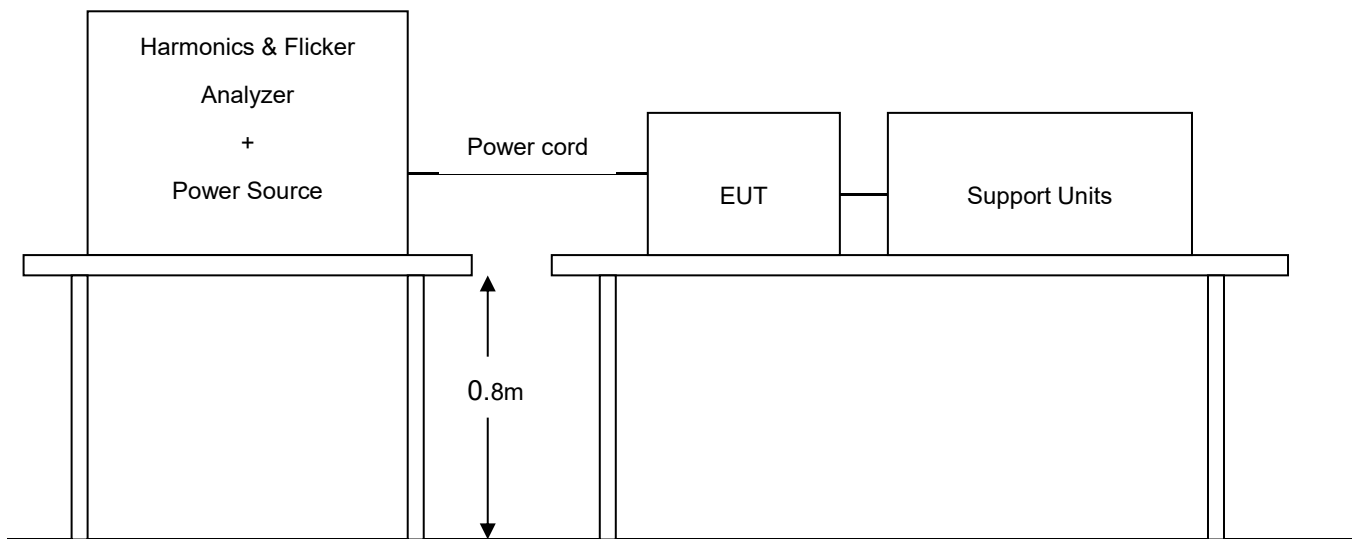

9.2. RESULT

Test Specification

Test Frequency	50Hz	Test Voltage	230V AC
Waveform	Sine	Test Time	2.5min
Classification	Class A		

Note: 1. The active input power of the EUT is less than 75W.

2. Equipment with a rated power less than or equal to 75W is deemed to fulfil all relevant requirements of this standard without testing.

10. VOLTAGE FLUCTUATION / FLICKER TEST

VOLTAGE FLUCTUATION/FLICKER MEASUREMENT

Port	AC mains
Basic Standard	EN 61000-3-3
Limits	§5 of EN 61000-3-3
Temperature	23.9°C
Relative Humidity	62.3%

10.1. BLOCK DIAGRAM OF TEST SETUP

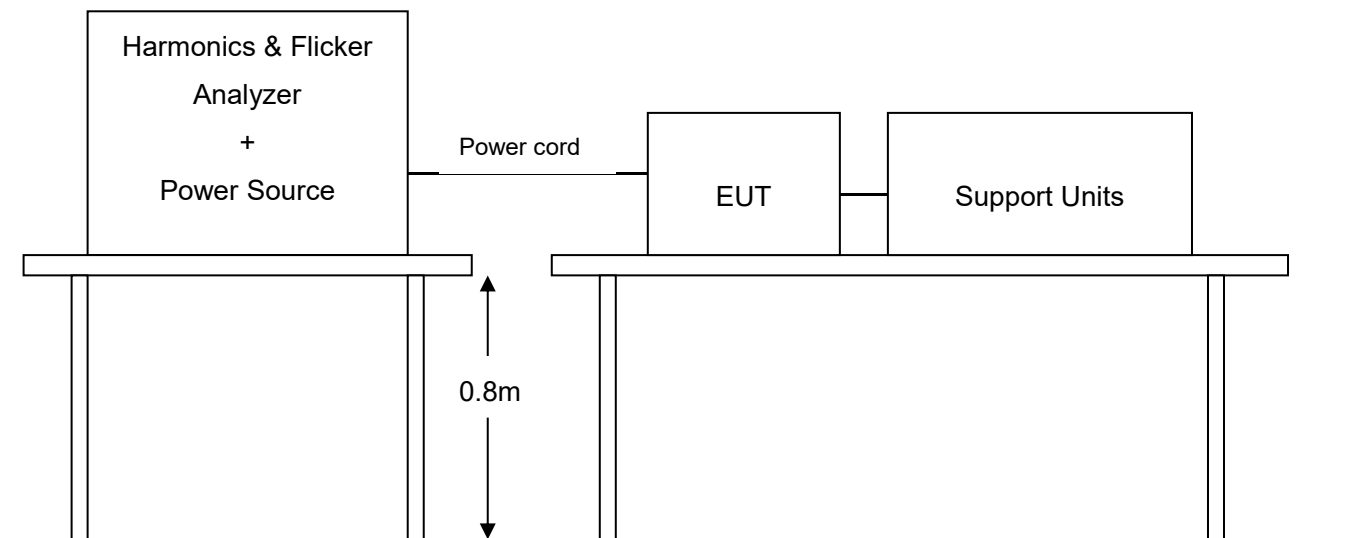

Any report having not been signed by authorized approver, or having been altered without authorization, or having not been stamped by the "Dedicated Testing/Inspection Stamp" is deemed to be invalid. Copying or excerpting portion of, or altering the content of the report is not permitted without the written authorization of AGC. The test results presented in the report apply only to the tested sample. Any objections to report issued by AGC should be submitted to AGC within 15days after the issuance of the test report. Further enquiry of validity or verification of the test report should be addressed to AGC by agc01@agccert.com.

10.2. RESULT**Flicker Test Summary per EN/IEC61000-3-3 (Run time)**

Test Parameter	Measurement Value	Limit	Remarks
Time(mS) > dt:	0.0	500.0	Pass
Highest dc (%):	0.00	3.30	Pass
Highest dmax (%):	0.00	4.00	Pass
Highest Pst (10 min. period):	0.248	1.0	Pass
Highest Plt (2 hr. period):	0.108	0.65	Pass

Any report having not been signed by authorized approver, or having been altered without authorization, or having not been stamped by the "Dedicated Testing/Inspection Stamp" is deemed to be invalid. Copying or excerpting portion of, or altering the content of the report is not permitted without the written authorization of AGC. The test results presented in the report apply only to the tested sample. Any objections to report issued by AGC should be submitted to AGC within 15days after the issuance of the test report. Further enquiry of validity or verification of the test report should be addressed to AGC by agc01@agccert.com.

11. ESD IMMUNITY TEST
ELECTROSTATIC DISCHARGE (ESD) IMMUNITY TEST

Port	Enclosure
Basic Standard	EN 61000-4-2
Test Level	± 8.0 kV (Air Discharge) ± 4.0 kV (Contact Discharge) ± 4.0 kV (Indirect Discharge)
Standard require	B
Temperature	23°C
Relative Humidity	47%

11.1. BLOCK DIAGRAM OF TEST SETUP

(The 470 k ohm resistors are installed per standard requirement)

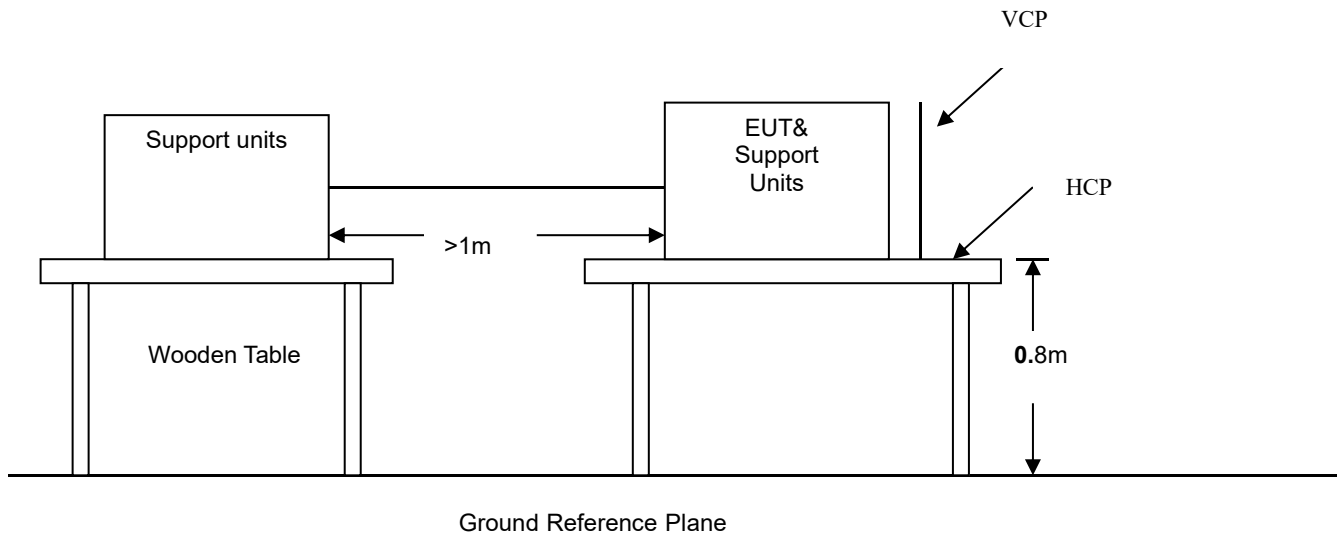

For the actual test configuration, please refer to Appendix A: Photographs of the Test Configuration.

Any report having not been signed by authorized approver, or having been altered without authorization, or having not been stamped by the "Dedicated Testing/Inspection Stamp" is deemed to be invalid. Copying or excerpting portion of, or altering the content of the report is not permitted without the written authorization of AGC. The test results presented in the report apply only to the tested sample. Any objections to report issued by AGC should be submitted to AGC within 15days after the issuance of the test report. Further enquiry of validity or verification of the test report should be addressed to AGC by agc01@agccert.com.

11.2. TEST PROCEDURE

The EUT was located 0.1 m minimum from all side of the HCP.

The support units were located 1 m minimum away from the EUT.

EUT worked with resistance load, and make sure EUT worked normally.

Activates the communication function if the EUT with such port(s).

As per the requirement of EN 55035: Contact discharge is the preferred test method. 20 discharges (10 with positive and 10 negative polarity) shall be applied on each accessible metal part of the enclosure. In case of a non-conductive enclosure, discharges shall be applied on the horizontal or vertical coupling planes as specified in EN 61000-4-2.

Air discharges shall be used where contact discharges cannot be applied.

The following test condition was followed during the tests.

Note: As per the A2 to EN 61000-4-2, a bleed resistor cable is connected between the EUT and HCP during the test.

The electrostatic discharges were applied as follows:

11.3. PERFORMANCE & RESULT

Amount of Discharges	Voltage	Coupling	Performance	Conclusion
Mini 20 /Point	±4kV	Contact Discharge	A	PASS
Mini 20 /Point	±4kV	Indirect Discharge HCP (Front)	A	PASS
Mini 20 /Point	±4kV	Indirect Discharge HCP (Left)	A	PASS
Mini 20 /Point	±4kV	Indirect Discharge HCP (Back)	A	PASS
Mini 20 /Point	±4kV	Indirect Discharge HCP (Right)	A	PASS
Mini 20 /Point	±4kV	Indirect Discharge VCP (Front)	A	PASS
Mini 20 /Point	±4kV	Indirect Discharge VCP (Left)	A	PASS
Mini 20 /Point	±4kV	Indirect Discharge VCP (Back)	A	PASS
Mini 20 /Point	±4kV	Indirect Discharge VCP (Right)	A	PASS
Mini 20 /Point	±8kV	Air Discharge	A	PASS

Any report having not been signed by authorized approver, or having been altered without authorization, or having not been stamped by the "Dedicated Testing/Inspection Stamp" is deemed to be invalid. Copying or excerpting portion of, or altering the content of the report is not permitted without the written authorization of AGC. The test results presented in the report apply only to the tested sample. Any objections to report issued by AGC should be submitted to AGC within 15days after the issuance of the test report. Further enquiry of validity or verification of the test report should be addressed to AGC by agc01@agccert.com.

ESD LOCATION:

Blue line: Air discharge

Red line: Contact discharge



Any report having not been signed by authorized approver, or having been altered without authorization, or having not been stamped by the "Dedicated Testing/Inspection Stamp" is deemed to be invalid. Copying or excerpting portion of, or altering the content of the report is not permitted without the written authorization of AGC. The test results presented in the report apply only to the tested sample. Any objections to report issued by AGC should be submitted to AGC within 15days after the issuance of the test report. Further enquiry of validity or verification of the test report should be addressed to AGC by agc01@agccert.com.

11.4. PERFORMANCE

<input checked="" type="checkbox"/> Criteria A:	The apparatus continues to operate as intended. No degradation of performance or loss of function is allowed below a performance level specified by the manufacturer, when the apparatus is used as intended. In some cases the performance level may be replaced by a permissible loss of performance.
<input type="checkbox"/> Criteria B:	The apparatus continues to operate as intended after the test. No degradation of performance or loss of function is allowed below a performance level specified by the manufacturer, when the apparatus is used as intended. In some cases the performance level may be replaced by a permissible loss of performance. During the test, degradation of performance is however allowed.
<input type="checkbox"/> Criteria C:	Temporary loss of function is allowed, provided the functions self recoverable or can be restored by the operation of controls.

<input checked="" type="checkbox"/> Compliance <input type="checkbox"/> Not Compliance
--

Any report having not been signed by authorized approver, or having been altered without authorization, or having not been stamped by the "Dedicated Testing/Inspection Stamp" is deemed to be invalid. Copying or excerpting portion of, or altering the content of the report is not permitted without the written authorization of AGC. The test results presented in the report apply only to the tested sample. Any objections to report issued by AGC should be submitted to AGC within 15days after the issuance of the test report. Further enquiry of validity or verification of the test report should be addressed to AGC by agc01@agccert.com.

12. RADIATED, RADIO FREQUENCY ELECTROMAGNETIC FIELD IMMUNITY TEST

12.1. TEST SPECIFICATION

Basic Standard	EN 61000-4-3
Frequency Range	80-1000, 1800, 2600, 3500, 5000(MHz)
Field Strength	3V/m
Modulation	1 kHz sine wave, 80%, AM modulation
Frequency Step	1% of fundamental
Polarity of Antenna	Horizontal and Vertical
Test Distance	3m
Antenna Height	1.5m
Dwell Time	3 seconds

12.2. TEST PROCEDURE

The test procedure was in accordance with EN 61000-4-3.

- a. The testing was performed in a fully anechoic chamber. The transmit antenna was located at a distance of 3 meters from the EUT.
- b. The test signal was 80% amplitude modulated with a 1 kHz sine wave.
- c. The frequency range was swept at 80-1000, 1800, 2600, 3500, 5000(MHz) with the exception of the exclusion band for transmitters, receivers and duplex transceivers. The rate of sweep did not exceed 1.5×10^{-3} decade/s. Where the frequency range is swept incrementally, the step size was 1% of fundamental.
- d. The dwell time at each frequency shall be not less than the time necessary for the EUT to be able to respond.
- e. The field strength level was 3V/m.
- f. The test was performed with the EUT exposed to both vertically and horizontally polarized fields on each of the four sides.

Any report having not been signed by authorized approver, or having been altered without authorization, or having not been stamped by the "Dedicated Testing/Inspection Stamp" is deemed to be invalid. Copying or excerpting portion of, or altering the content of the report is not permitted without the written authorization of AGC. The test results presented in the report apply only to the tested sample. Any objections to report issued by AGC should be submitted to AGC within 15days after the issuance of the test report. Further enquiry of validity or verification of the test report should be addressed to AGC by agc01@agccert.com.

12.3. TEST SETUP

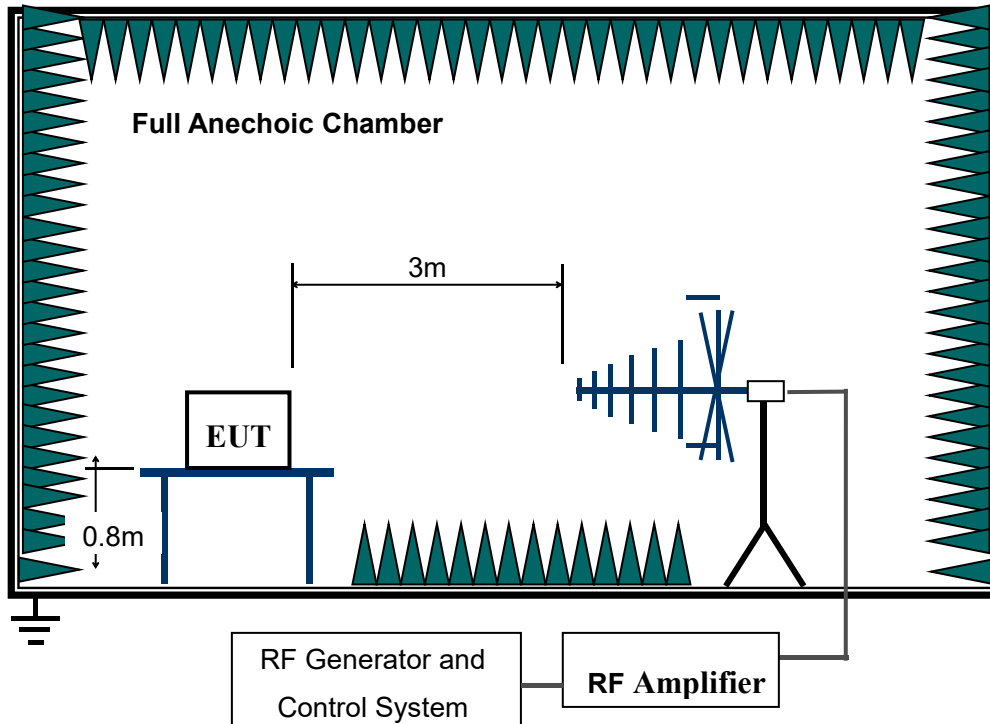

For the actual test configuration, please refer to Appendix A: Photographs of the Test Configuration.

Any report having not been signed by authorized approver, or having been altered without authorization, or having not been stamped by the “Dedicated Testing/Inspection Stamp” is deemed to be invalid. Copying or excerpting portion of, or altering the content of the report is not permitted without the written authorization of AGC. The test results presented in the report apply only to the tested sample. Any objections to report issued by AGC should be submitted to AGC within 15days after the issuance of the test report. Further enquiry of validity or verification of the test report should be addressed to AGC by agc01@agccert.com.

12.4. TEST RESULT

Freq. Range (MHz)	Field	Modulation	Polarity	Position	Observation	performance	Conclusion
80-1000,1800,2600,3500,5000	3V/m	Yes	H / V	Front	No Function Loss	A	PASS
80-1000,1800,2600,3500,5000	3V/m	Yes	H / V	Back	No Function Loss	A	PASS
80-1000,1800,2600,3500,5000	3V/m	Yes	H / V	Left	No Function Loss	A	PASS
80-1000,1800,2600,3500,5000	3V/m	Yes	H / V	Right	No Function Loss	A	PASS
80-1000,1800,2600,3500,5000	3V/m	Yes	H / V	Top	No Function Loss	A	PASS
80-1000,1800,2600,3500,5000	3V/m	Yes	H / V	Bottom	No Function Loss	A	PASS

Note: operating mode include all modes of EMS in page 6.

12.5. PERFORMANCE

<input checked="" type="checkbox"/> Criteria A:	The apparatus continues to operate as intended. No degradation of performance or loss of function is allowed below a performance level specified by the manufacturer, when the apparatus is used as intended. In some cases the performance level may be replaced by a permissible loss of performance. The measured acoustic interference ratio during the test are less than -20 dB.
<input type="checkbox"/> Criteria B:	The apparatus continues to operate as intended after the test. No degradation of performance or loss of function is allowed below a performance level specified by the manufacturer, when the apparatus is used as intended. In some cases the performance level may be replaced by a permissible loss of performance. During the test, degradation of performance is however allowed.
<input type="checkbox"/> Criteria C:	Temporary loss of function is allowed, provided the functions self recoverable or can be restored by the operation of controls.
<input checked="" type="checkbox"/> Compliance <input type="checkbox"/> Not Compliance	

Any report having not been signed by authorized approver, or having been altered without authorization, or having not been stamped by the "Dedicated Testing/Inspection Stamp" is deemed to be invalid. Copying or excerpting portion of, or altering the content of the report is not permitted without the written authorization of AGC. The test results presented in the report apply only to the tested sample. Any objections to report issued by AGC should be submitted to AGC within 15days after the issuance of the test report. Further enquiry of validity or verification of the test report should be addressed to AGC by agc01@agccert.com.

13. ELECTRICAL FAST TRANSIENT/BURST IMMUNITY TEST

13.1. TEST SPECIFICATION

Basic Standard	EN 61000-4-4
Test Voltage	a.c. power port $\pm 1\text{kV}$
Polarity	Positive/Negative
Impulse Frequency	5kHz
Impulse wave shape	5/50ns
Burst Duration	15ms
Burst Period	300ms
Test Duration	Not less than 1 min.

13.2. TEST PROCEDURE

1. The EUT was tested with 1000 volt discharges to the AC power input leads.
2. Both positive and negative polarity discharges were applied.
3. The length of the “hot wire” from the coaxial output of the EFT generator to the terminals on the EUT should not exceed 1 meter.
4. The duration time of each test sequential was 1 minute.
5. The transient/burst waveform was in accordance with EN 61000-4-4, 5/50ns.

13.3. TEST SETUP

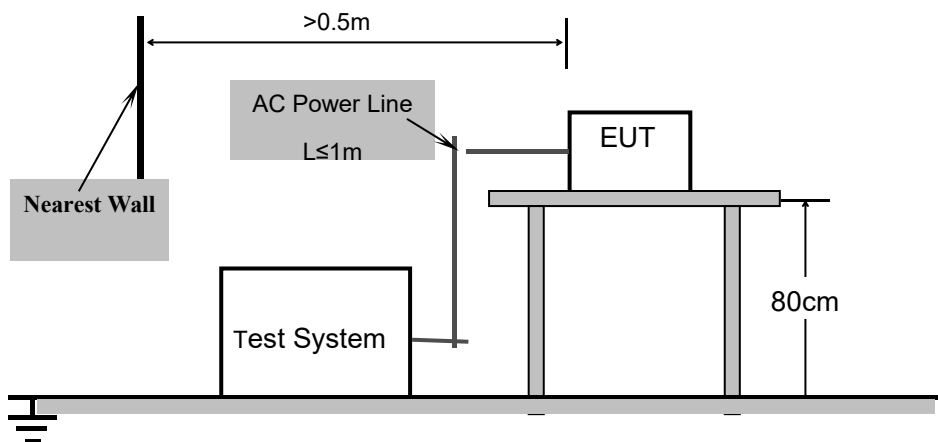

For the actual test configuration, please refer to Appendix A: Photographs of the Test Configuration.

Any report having not been signed by authorized approver, or having been altered without authorization, or having not been stamped by the “Dedicated Testing/Inspection Stamp” is deemed to be invalid. Copying or excerpting portion of, or altering the content of the report is not permitted without the written authorization of AGC. The test results presented in the report apply only to the tested sample. Any objections to report issued by AGC should be submitted to AGC within 15days after the issuance of the test report. Further enquiry of validity or verification of the test report should be addressed to AGC by agc01@agccert.com.

13.4. TEST RESULT

Test Point	Polarity	Test Level (kV)	Observation	performance	Conclusion
a.c. port, L	+/-	1	No function loss	A	Pass
a.c. port, N	+/-	1	No function loss	A	Pass
a.c. port, L-N	+/-	1	No function loss	A	Pass

Note: operating mode include all modes of EMS in page 6.

13.5. PERFORMANCE

<input checked="" type="checkbox"/> Criteria A:	The apparatus continues to operate as intended. No degradation of performance or loss of function is allowed below a performance level specified by the manufacturer, when the apparatus is used as intended. In some cases the performance level may be replaced by a permissible loss of performance.
<input type="checkbox"/> Criteria B:	The apparatus continues to operate as intended after the test. No degradation of performance or loss of function is allowed below a performance level specified by the manufacturer, when the apparatus is used as intended. In some cases the performance level may be replaced by a permissible loss of performance. During the test, degradation of performance is however allowed.
<input type="checkbox"/> Criteria C:	Temporary loss of function is allowed, provided the functions self recoverable or can be restored by the operation of controls.

Compliance **Not Compliance**

Any report having not been signed by authorized approver, or having been altered without authorization, or having not been stamped by the "Dedicated Testing/Inspection Stamp" is deemed to be invalid. Copying or excerpting portion of, or altering the content of the report is not permitted without the written authorization of AGC. The test results presented in the report apply only to the tested sample. Any objections to report issued by AGC should be submitted to AGC within 15days after the issuance of the test report. Further enquiry of validity or verification of the test report should be addressed to AGC by agc01@agccert.com.

14. SURGE IMMUNITY TEST

14.1. TEST SPECIFICATION

Basic Standard	EN 61000-4-5
Waveform	Voltage 1.2/50 μ s; Current 8/20 μ s
Test Voltage	a.c. power port, line to line \pm 1.0 kV
Polarity	Positive/Negative
Phase Angle	90°, 270°
Repetition Rate	60sec
Times	5 time/each condition.

14.2. TEST PROCEDURE

- The EUT and the auxiliary equipment were placed on a table of 0.8m heights above a metal ground reference plane. The size of ground plane is greater than 1m \times 1m and project beyond the EUT by at least 0.1m on all sides. The ground plane is connected to the protective earth. The length of power cord between the coupling device and the EUT was less than 2 meters (provided by the manufacturer).
- The EUT was connected to the power mains through a coupling device that directly couples the surge interference signal. The surge noise was applied synchronized to the voltage phase at the zero crossing and the peak value of the AC voltage wave (positive and negative).
- The surges were applied line to line and line(s) to earth. When testing line to earth the test voltage was applied successively between each of the lines and earth. Steps up to the test level specified increased the test voltage. All lower levels including the selected test level were tested. The polarity of each surge level included positive and negative test pulses.

14.3. TEST SETUP

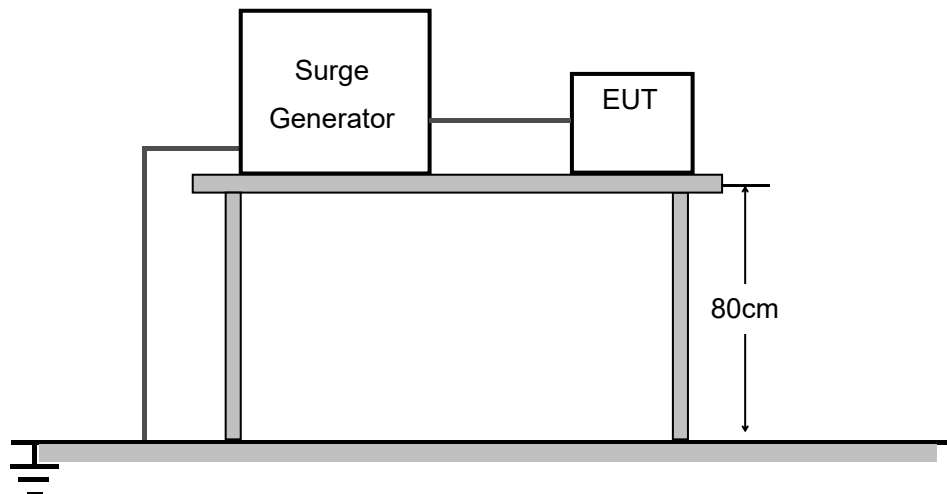

For the actual test configuration, please refer to Appendix A: Photographs of the Test Configuration.

Any report having not been signed by authorized approver, or having been altered without authorization, or having not been stamped by the "Dedicated Testing/Inspection Stamp" is deemed to be invalid. Copying or excerpting portion of, or altering the content of the report is not permitted without the written authorization of AGC. The test results presented in the report apply only to the tested sample. Any objections to report issued by AGC should be submitted to AGC within 15days after the issuance of the test report. Further enquiry of validity or verification of the test report should be addressed to AGC by agc01@agccert.com.

14.4. TEST RESULT

Coupling Line	Polarity	Voltage (kV)	Observation	performance	Conclusion
a.c. power, L-N	+/-	1.0	No function loss	A	Pass

Note: operating mode include all modes of EMS in page 6.

14.5. PERFORMANCE

<input checked="" type="checkbox"/> Criteria A:	The apparatus continues to operate as intended. No degradation of performance or loss of function is allowed below a performance level specified by the manufacturer, when the apparatus is used as intended. In some cases the performance level may be replaced by a permissible loss of performance.
<input type="checkbox"/> Criteria B:	The apparatus continues to operate as intended after the test. No degradation of performance or loss of function is allowed below a performance level specified by the manufacturer, when the apparatus is used as intended. In some cases the performance level may be replaced by a permissible loss of performance. During the test, degradation of performance is however allowed.
<input type="checkbox"/> Criteria C:	Temporary loss of function is allowed, provided the functions self recoverable or can be restored by the operation of controls.

<input checked="" type="checkbox"/> Compliance <input type="checkbox"/> Not Compliance
--

Any report having not been signed by authorized approver, or having been altered without authorization, or having not been stamped by the "Dedicated Testing/Inspection Stamp" is deemed to be invalid. Copying or excerpting portion of, or altering the content of the report is not permitted without the written authorization of AGC. The test results presented in the report apply only to the tested sample. Any objections to report issued by AGC should be submitted to AGC within 15days after the issuance of the test report. Further enquiry of validity or verification of the test report should be addressed to AGC by agc01@agccert.com.

15. IMMUNITY TO CONDUCTED DISTURBANCES INDUCED BY RF FIELDS

15.1. TEST SPECIFICATION

Basic Standard	EN 61000-4-6
Frequency Range	0.15 MHz – 80 MHz
Field Strength	0.15~10MHz 3Vrms,10~30MHz 3 to 1Vrms,30~80MHz 1Vrms
Modulation	1 kHz Sine Wave, 80% AM
Frequency Step	1% of fundamental
Coupled Cable	a.c. power line
Coupling Device	CDN-M2

15.2. TEST PROCEDURE

1. The EUT shall be tested within its intended operating and climatic conditions.
2. The test shall be performed with the test generator connected to each of the coupling and decoupling devices in turn, while the other non-excited RF input ports of the coupling devices are terminated by a 50-ohm load resistor.
3. The test signal was 80% amplitude modulated with a 1 kHz sine wave
4. The frequency range is swept from 150 kHz to 80 MHz, using the signal level established during the setting process and with a disturbance signal of 80% amplitude. The sweep rate shall not exceed 1.5×10^{-3} decades/s. The step size shall not exceed 1% of the start and thereafter 1% of the preceding frequency value where the frequency is swept incrementally.
5. The dwell time at each frequency shall not be less than the time necessary for the EUT to be exercised, and able to respond. Sensitive frequencies such as clock frequencies and harmonics or frequencies of dominant interest, shall be analyzed separately.
6. Attempts should be made to fully exercise the EUT during test, and to fully interrogate all exercise modes selected for susceptibility.

15.3. TEST SETUP

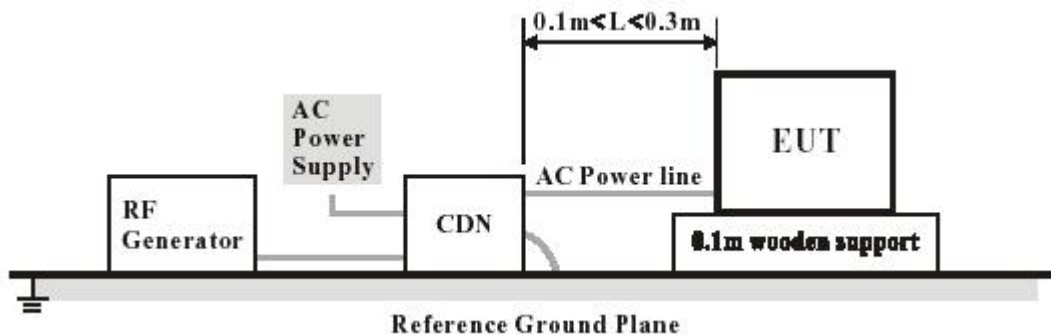

For the actual test configuration, please refer to Appendix A: Photographs of the Test Configuration.

Any report having not been signed by authorized approver, or having been altered without authorization, or having not been stamped by the “Dedicated Testing/Inspection Stamp” is deemed to be invalid. Copying or excerpting portion of, or altering the content of the report is not permitted without the written authorization of AGC. The test results presented in the report apply only to the tested sample. Any objections to report issued by AGC should be submitted to AGC within 15days after the issuance of the test report. Further enquiry of validity or verification of the test report should be addressed to AGC by agc01@agccert.com.

15.4. TEST RESULT

EUT Working Mode	Test Point	Frequency (MHz)	Field Strength (Vrms)	Observation	performance	Conclusion
Normal	a.c. port	0.15 – 10	3	No function loss	A	Pass
Normal	a.c. port	10 – 30	3 to1	No function loss	A	Pass
Normal	a.c. port	30 – 80	1	No function loss	A	Pass

Note: operating mode include all modes of EMS in page 6.

15.5. PERFORMANCE

<input checked="" type="checkbox"/> Criteria A:	The apparatus continues to operate as intended. No degradation of performance or loss of function is allowed below a performance level specified by the manufacturer, when the apparatus is used as intended. In some cases the performance level may be replaced by a permissible loss of performance. The measured acoustic interference ratio during the test are less than -20 dB.
<input type="checkbox"/> Criteria B:	The apparatus continues to operate as intended after the test. No degradation of performance or loss of function is allowed below a performance level specified by the manufacturer, when the apparatus is used as intended. In some cases the performance level may be replaced by a permissible loss of performance. During the test, degradation of performance is however allowed.
<input type="checkbox"/> Criteria C:	Temporary loss of function is allowed, provided the functions self recoverable or can be restored by the operation of controls.

Compliance **Not Compliance**

16. VOLTAGE DIPS AND SHORT INTERRUPTIONS IMMUNITY TEST

16.1. TEST SPECIFICATION

Basic Standard	EN 61000-4-11
Voltage Dips	100% reduction, 0.5 Cycle 30% reduction, 25 Cycles
Voltage Interruptions	100% reduction, 250 Cycles
Voltage Phase Angle	0°, 45°, 90°, 135°, 180°, 225°, 270°, 315°

16.2. TEST PROCEDURE

- The power cord was used as supplied by the manufacturer. The EUT was connected to the line output of the Voltage Dips and Interruption Generator.
- The EUT was tested for (1) 100% voltage dip of supplied voltage with duration of 0.5 cycles, (2) 30% voltage dip of supplied voltage and duration 25 cycles. (3) 100% voltage interruption of supplied voltage with duration of 250 Cycles was followed.
- Voltage reductions occur at 0 degree crossover point of the voltage waveform. The performance of the EUT was checked after the voltage dip or interruption.

16.3. TEST SETUP

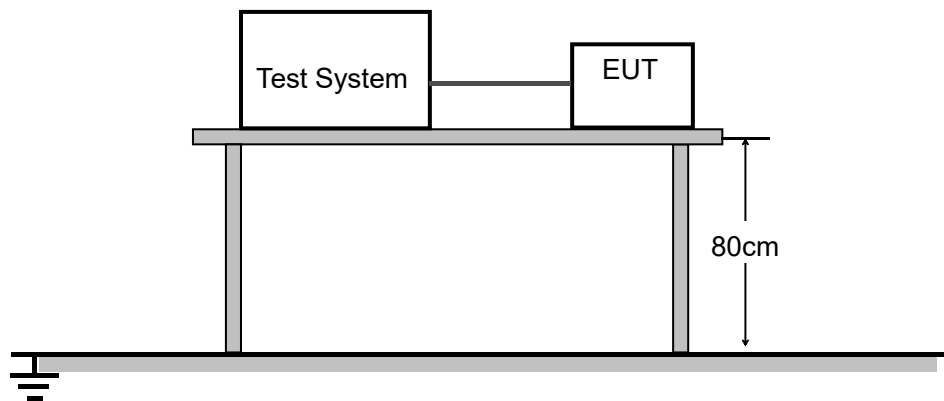

For the actual test configuration, please refer to Appendix A: Photographs of the Test Configuration.

16.4. TEST RESULT

Test Mode	Voltage Reduction	Duration (cycle)	Times	Interval (ms)	Observation	performance	Conclusion
Voltage dips	100%	0.5	3	10	No function loss	A	Pass
	30%	25	3	500	No function loss	A	Pass
Voltage interruptions	100%	250	3	5000	No function loss	B	Pass

Note: operating mode include all modes of EMS in page 6.

16.5. PERFORMANCE

<input checked="" type="checkbox"/> Criteria A:	The apparatus continues to operate as intended. No degradation of performance or loss of function is allowed below a performance level specified by the manufacturer, when the apparatus is used as intended. In some cases the performance level may be replaced by a permissible loss of performance.
<input checked="" type="checkbox"/> Criteria B:	The apparatus continues to operate as intended after the test. No degradation of performance or loss of function is allowed below a performance level specified by the manufacturer, when the apparatus is used as intended. In some cases the performance level may be replaced by a permissible loss of performance. During the test, degradation of performance is however allowed.
<input type="checkbox"/> Criteria C:	Temporary loss of function is allowed, provided the functions self recoverable or can be restored by the operation of controls.

Compliance **Not Compliance**

Any report having not been signed by authorized approver, or having been altered without authorization, or having not been stamped by the "Dedicated Testing/Inspection Stamp" is deemed to be invalid. Copying or excerpting portion of, or altering the content of the report is not permitted without the written authorization of AGC. The test results presented in the report apply only to the tested sample. Any objections to report issued by AGC should be submitted to AGC within 15days after the issuance of the test report. Further enquiry of validity or verification of the test report should be addressed to AGC by agc01@agccert.com.

APPENDIX A: PHOTOGRAPHS OF TEST SETUP

LINE CONDUCTED EMISSION TEST SETUP

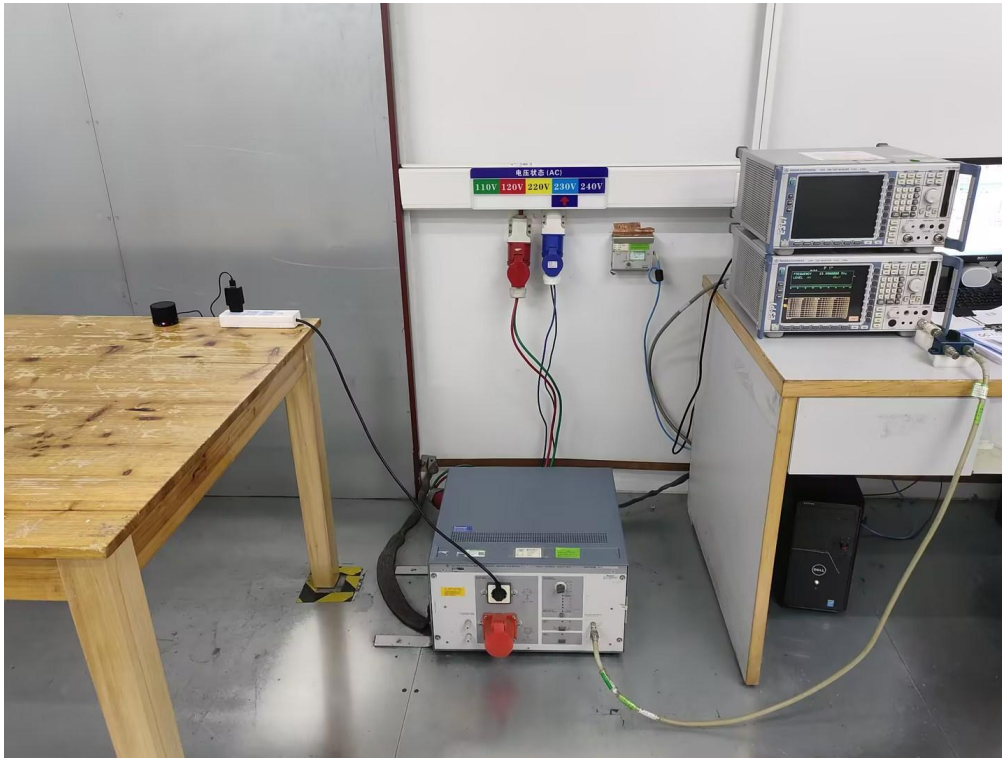

RADIATED EMISSION TEST SETUP (Below 1GHz)

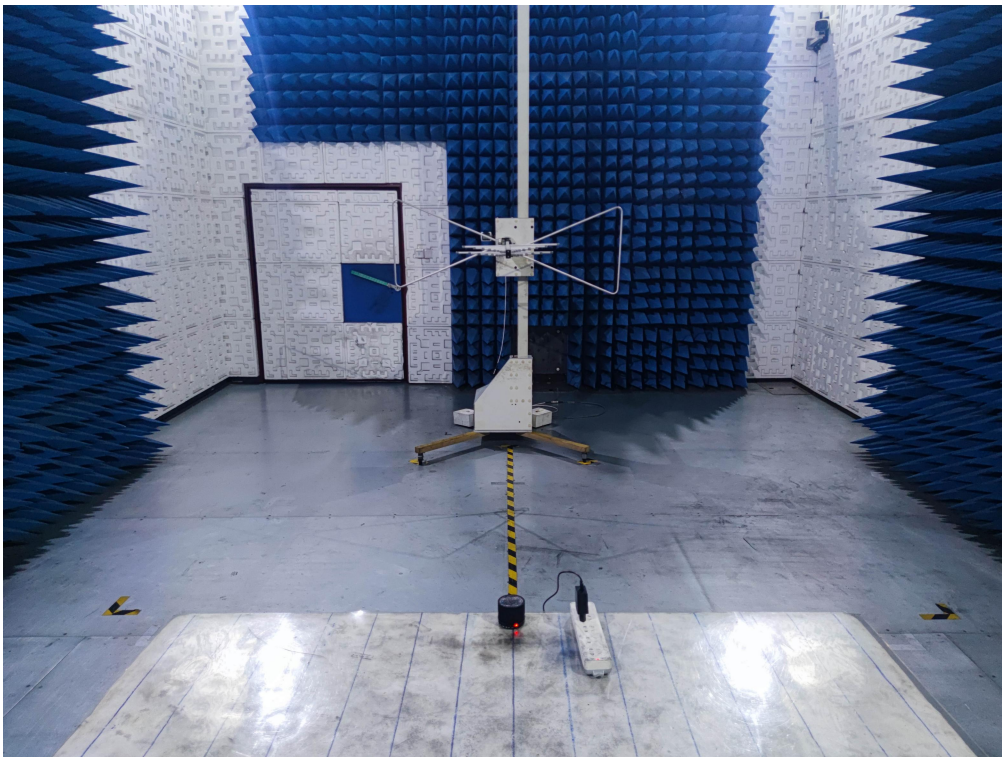

Any report having not been signed by authorized approver, or having been altered without authorization, or having not been stamped by the "Dedicated Testing/Inspection Stamp" is deemed to be invalid. Copying or excerpting portion of, or altering the content of the report is not permitted without the written authorization of AGC. The test results presented in the report apply only to the tested sample. Any objections to report issued by AGC should be submitted to AGC within 15days after the issuance of the test report. Further enquiry of validity or verification of the test report should be addressed to AGC by agc01@agccert.com.

RADIATED EMISSION TEST SETUP (Above 1GHz)

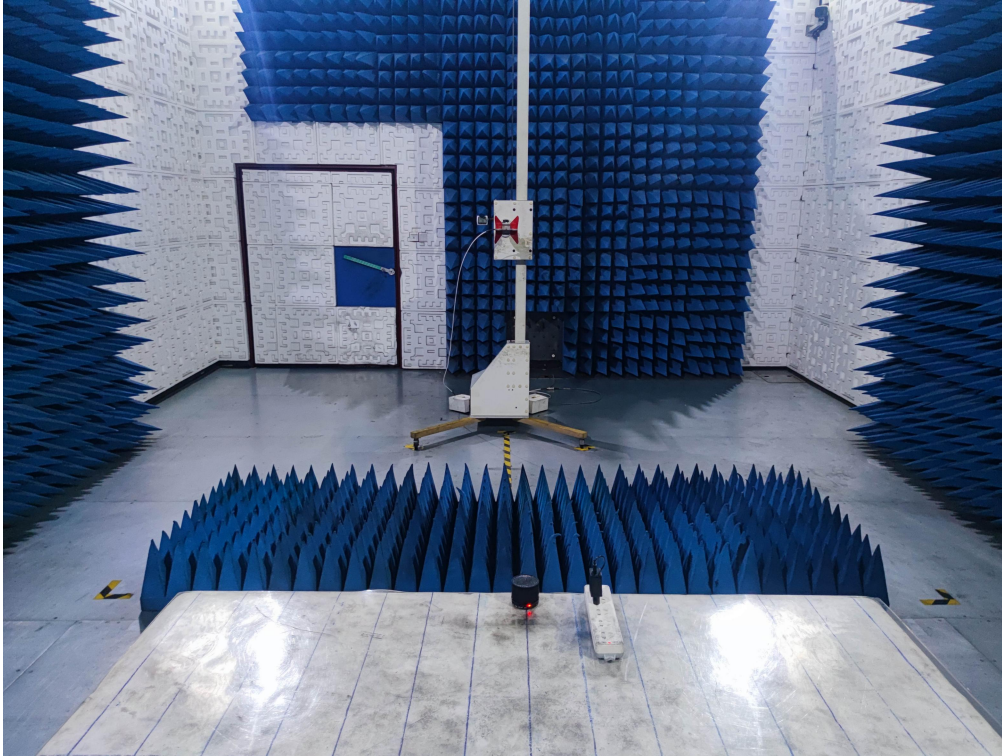

EN61000-3-3 VOLTAGE FLUCTUATION AND FLICKER TEST SETUP



Any report having not been signed by authorized approver, or having been altered without authorization, or having not been stamped by the “Dedicated Testing/Inspection Stamp” is deemed to be invalid. Copying or excerpting portion of, or altering the content of the report is not permitted without the written authorization of AGC. The test results presented in the report apply only to the tested sample. Any objections to report issued by AGC should be submitted to AGC within 15 days after the issuance of the test report. Further enquiry of validity or verification of the test report should be addressed to AGC by agc01@agccert.com.

Attestation of Global Compliance(Shenzhen)Co., Ltd
Attestation of Global Compliance(Shenzhen)Std & Tech Co., Ltd
Tel: +86-755 2523 4088 E-mail: agc@agccert.com Web: <http://www.agccert.com/>

EN 61000-4-2 ESD TEST SETUP

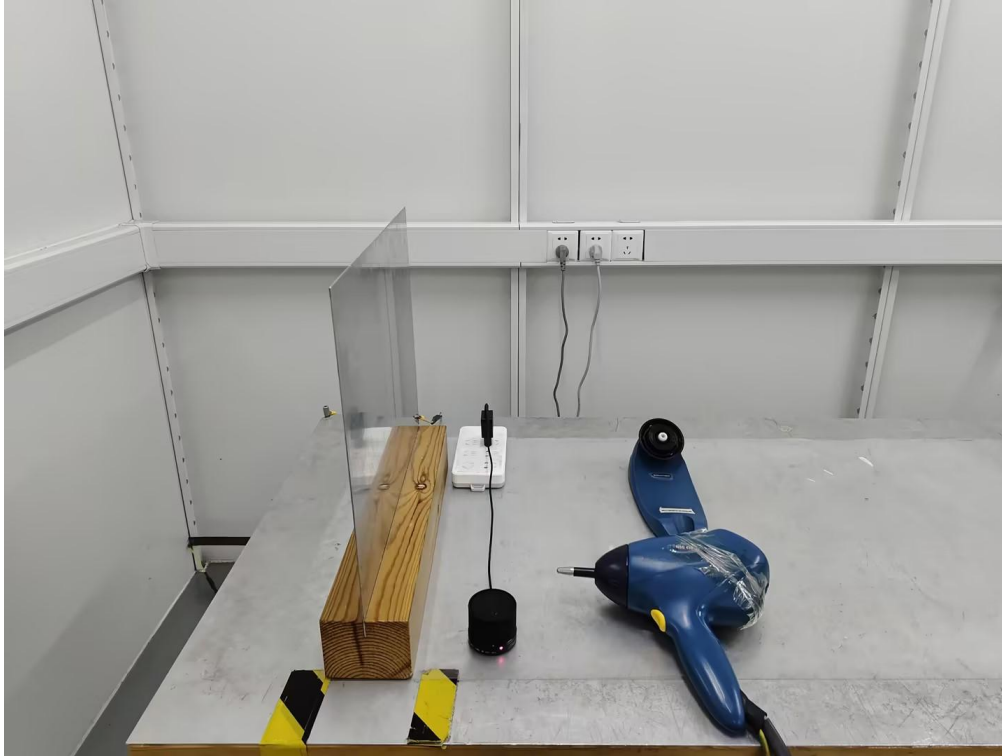

EN 61000-4-3 RS TEST SETUP (Below 1GHz)

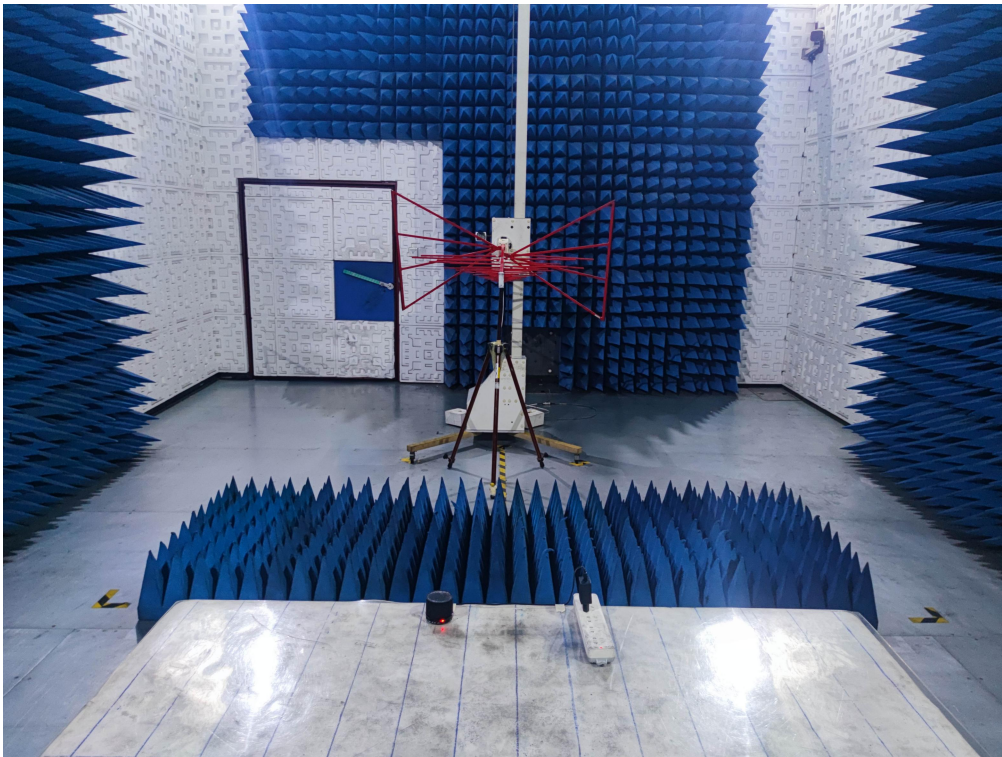

Any report having not been signed by authorized approver, or having been altered without authorization, or having not been stamped by the “Dedicated Testing/Inspection Stamp” is deemed to be invalid. Copying or excerpting portion of, or altering the content of the report is not permitted without the written authorization of AGC. The test results presented in the report apply only to the tested sample. Any objections to report issued by AGC should be submitted to AGC within 15days after the issuance of the test report. Further enquiry of validity or verification of the test report should be addressed to AGC by agc01@agccert.com.

EN 61000-4-3 RS TEST SETUP (Above 1GHz)

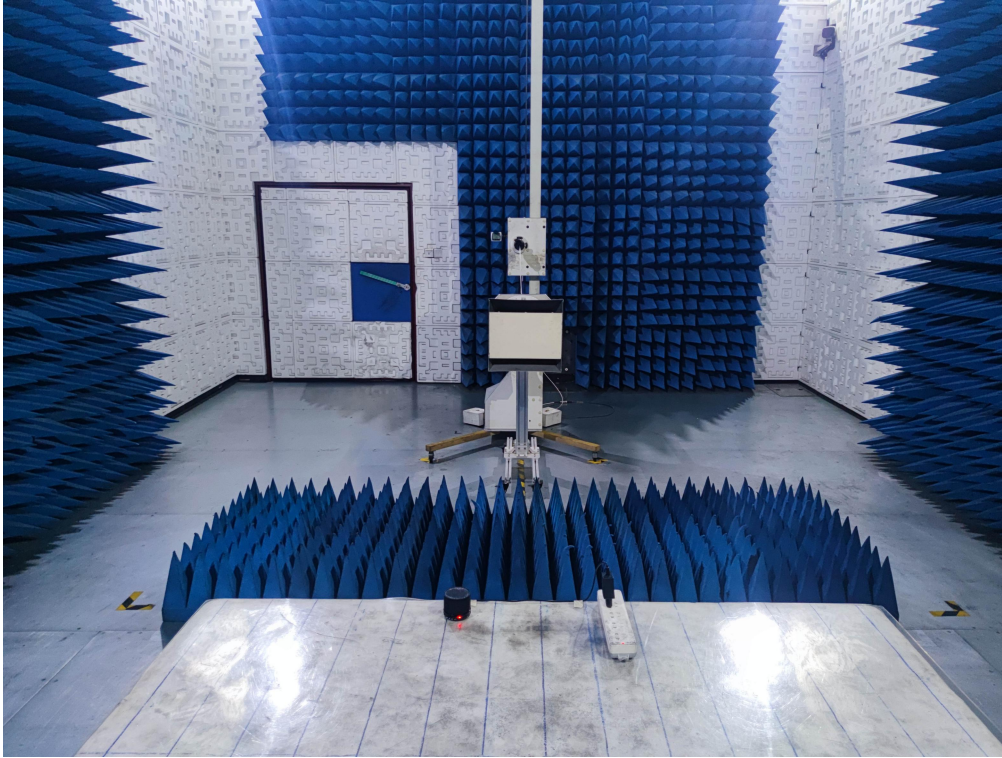

EN 61000-4-4/5/11 EFT/SURGE/DIPS IMMUNITY TEST SETUP

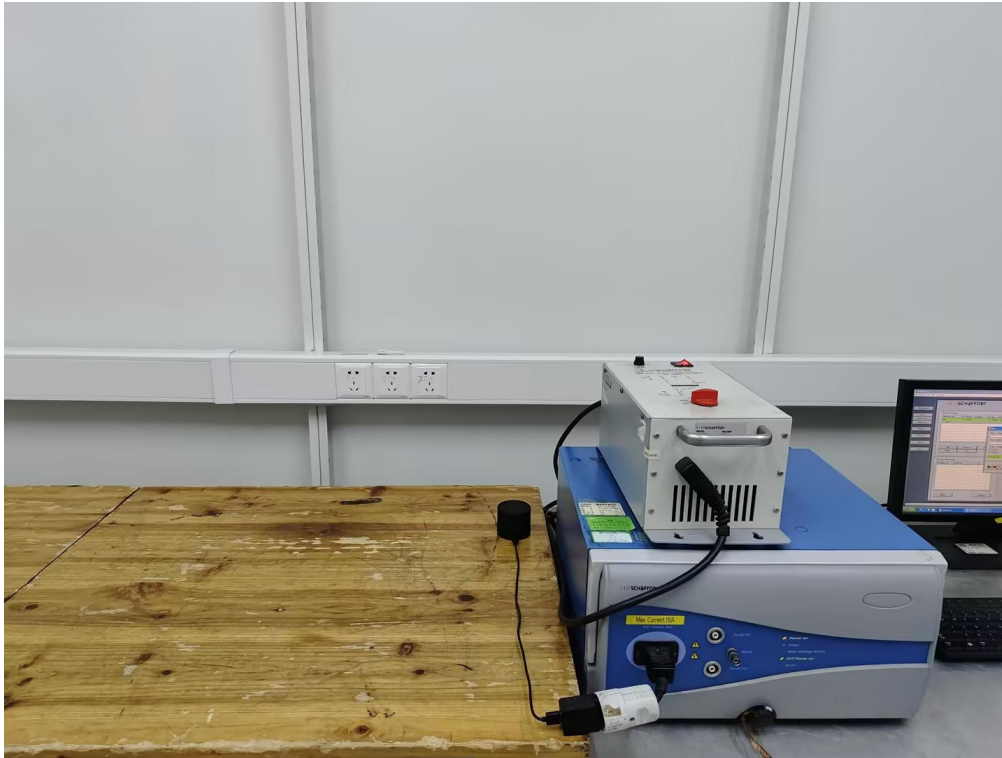

Any report having not been signed by authorized approver, or having been altered without authorization, or having not been stamped by the “Dedicated Testing/Inspection Stamp” is deemed to be invalid. Copying or excerpting portion of, or altering the content of the report is not permitted without the written authorization of AGC. The test results presented in the report apply only to the tested sample. Any objections to report issued by AGC should be submitted to AGC within 15days after the issuance of the test report. Further enquiry of validity or verification of the test report should be addressed to AGC by agc01@agccert.com.

EN 61000-4-6 CS IMMUNITY TEST SETUP

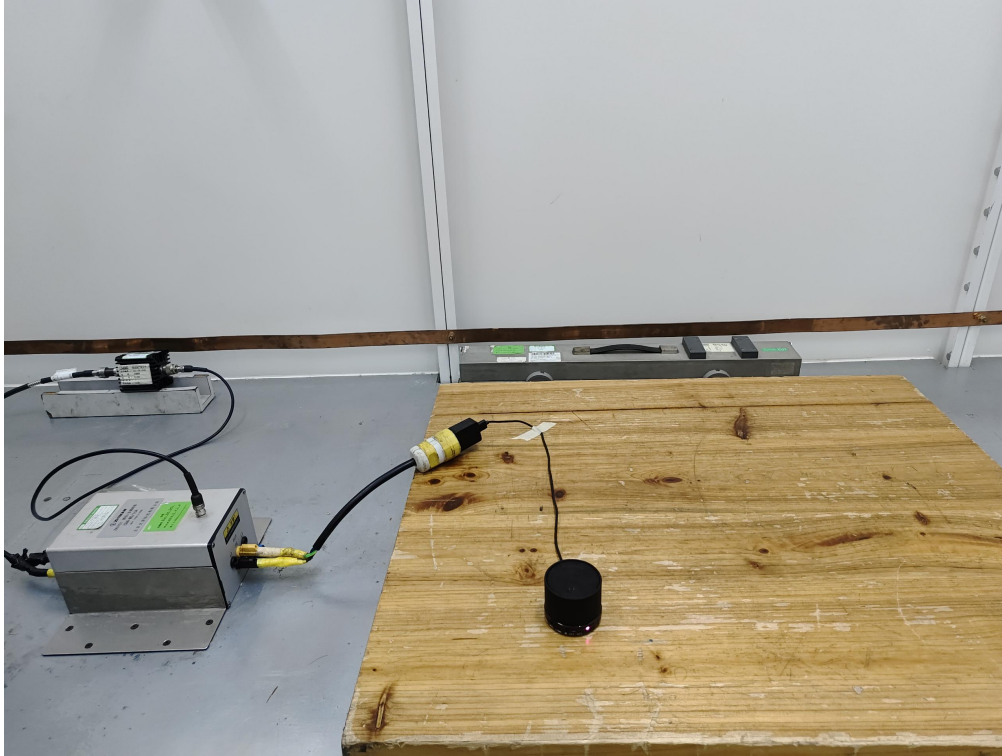

Any report having not been signed by authorized approver, or having been altered without authorization, or having not been stamped by the "Dedicated Testing/Inspection Stamp" is deemed to be invalid. Copying or excerpting portion of, or altering the content of the report is not permitted without the written authorization of AGC. The test results presented in the report apply only to the tested sample. Any objections to report issued by AGC should be submitted to AGC within 15days after the issuance of the test report. Further enquiry of validity or verification of the test report should be addressed to AGC by agc01@agccert.com.

Attestation of Global Compliance(Shenzhen)Co., Ltd
Attestation of Global Compliance(Shenzhen)Std & Tech Co., Ltd
Tel: +86-755 2523 4088 E-mail: agc@agccert.com Web: <http://www.agccert.com/>

APPENDIX B: PHOTOGRAPHS OF EUT

Refer to the Report No.: AGC12440230905AP01

----END OF REPORT----

Any report having not been signed by authorized approver, or having been altered without authorization, or having not been stamped by the “Dedicated Testing/Inspection Stamp” is deemed to be invalid. Copying or excerpting portion of, or altering the content of the report is not permitted without the written authorization of AGC. The test results presented in the report apply only to the tested sample. Any objections to report issued by AGC should be submitted to AGC within 15days after the issuance of the test report. Further enquiry of validity or verification of the test report should be addressed to AGC by agc01@agccert.com.

Attestation of Global Compliance(Shenzhen)Co., Ltd

Attestation of Global Compliance(Shenzhen)Std & Tech Co., Ltd

Tel: +86-755 2523 4088 E-mail: agc@agccert.com Web: <http://www.agccert.com/>



Conditions of Issuance of Test Reports

1. All samples and goods are accepted by the Attestation of Global Compliance (Shenzhen) Co., Ltd (the “Company”) solely for testing and reporting in accordance with the following terms and conditions. The company provides its services on the basis that such terms and conditions constitute express agreement between the company and any person, firm or company requesting its services (the “Clients”).
2. Any report issued by Company as a result of this application for testing services (the “Report”) shall be issued in confidence to the Clients and the Report will be strictly treated as such by the Company. It may not be reproduced either in its entirety or in part and it may not be used for advertising or other unauthorized purposes without the written consent of the Company. The Clients to whom the Report is issued may, however, show or send it, or a certified copy thereof prepared by the Company to its customer, supplier or other persons directly concerned. The Company will not, without the consent of the Clients, enter into any discussion or correspondence with any third party concerning the contents of the Report, unless required by the relevant governmental authorities, laws or court orders.
3. The Company shall not be called or be liable to be called to give evidence or testimony on the Report in a court of law without its prior written consent, unless required by the relevant governmental authorities, laws or court orders.
4. In the event of the improper use of the report as determined by the Company, the Company reserves the right to withdraw it, and to adopt any other additional remedies which may be appropriate.
5. Samples submitted for testing are accepted on the understanding that the Report issued cannot form the basis of, or be the instrument for, any legal action against the Company.
6. The Company will not be liable for or accept responsibility for any loss or damage however arising from the use of information contained in any of its Reports or in any communication whatsoever about its said tests or investigations.
7. Clients wishing to use the Report in court proceedings or arbitration shall inform the Company to that effect prior to submitting the sample for testing.
8. The Company is not responsible for recalling the electronic version of the original report when any revision is made to them. The Client assumes the responsibility to providing the revised version to any interested party who uses them.
9. Subject to the variable length of retention time for test data and report stored hereinto as otherwise specifically required by individual accreditation authorities, the Company will only keep the supporting test data and information of the test report for a period of six years. The data and information will be disposed of after the aforementioned retention period has elapsed. Under no circumstances shall we provide any data and information which has been disposed of after retention period. Under no circumstances shall we be liable for damage of any kind, including (but not limited to) compensatory damages, lost profits, lost data, or any form of special, incidental, indirect, consequential or punitive damages of any kind, whether based on breach of contract of warranty, tort (including negligence), product liability or otherwise, even if we are informed in advance of the possibility of such damages.

Any report having not been signed by authorized approver, or having been altered without authorization, or having not been stamped by the “Dedicated Testing/Inspection Stamp” is deemed to be invalid. Copying or excerpting portion of, or altering the content of the report is not permitted without the written authorization of AGC. The test results presented in the report apply only to the tested sample. Any objections to report issued by AGC should be submitted to AGC within 15days after the issuance of the test report. Further enquiry of validity or verification of the test report should be addressed to AGC by agc01@agccert.com.